



MASCHIO FIENAGIONE S.p.A.



PITAGORA

EN - OPERATOR'S MANUAL

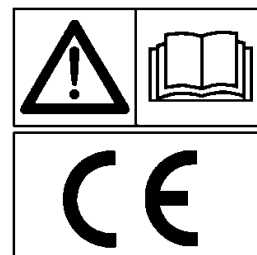

Cod. EKE0001OM

2019-05

*) Valido per Paesi UE
*) Valid for EU member countries
*) Valable dans les Pays UE
*) Gilt für EU-Mitgliedsländer
*) Válido para Países UE

Index

1. GENERAL INFORMATION	3
1.1. General Description	3
1.2. Intended Use	3
1.3. General Information	3
1.3.1. General Information	Errore. Il segnalibro non è definito.
1.3.2. Certification	3
1.3.3. Identification	4
1.3.4. Required Information for Questions and Orders	5
1.3.5. Operation Compatible with Intended Use	5
1.4. General Factors Regarding Environmental Science	5
2. TECHNICAL INFORMATION.....	6
2.1. Tractor Requirements	6
2.1. Technical Features of the Baler Machine	7
3. SAFETY.....	8
3.1. Determination of Safety Precautions in the User Guide	8
3.2. Explanations of Safety and Accident Preventer Regulations	8
3.3. Warnings and Precautions	9
3.4. Qualification and Training of Personnel.....	10
3.5. Failure on Practice of Safety Precautions	10
3.6. Secured and Conscious Working.....	10
3.7. Safety Precautions and Accident Preventer Regulations	11
3.7.1. Protection of Mechanical Systems	12
3.7.2. Processes of Linking Shaft	12
3.7.3. Hydraulic System	13
3.7.4. Tyres	13
3.7.5. Maintenance	13
3.8. Unauthorised Modification and Producing Modified Parts	14
3.9. Prohibited Forms of Operating	14
3.10. Introduction to the Machine.....	14
3.11. Safety Warnings on the Machine.....	14
3.12. Danger Area.....	16
4. INSTRUCTIONS OF MACHINE OPERATING.....	17
4.1. Leading Operation	17
4.1. Connecting of Tractor to Drawbar.....	17
4.2. Connecting and Disconnecting Jack System	18
4.3. Setting The Machine from Road Position to On Duty Position	18
4.1. Mounting of Shaft.....	19
4.2. Fixing of Shaft Guards	19
4.1. Connection of Hydraulic Hoses.....	20
4.2. Connection of Electrical System	20
4.3. Connection of Twines to the Machine Accurately	21
4.4. Adjusting of Support Wheels.....	21
4.5. Opening of Rear Hatch	22
4.1. Support Adjustment of Picking Gear.....	23
4.2. Form, Weight and Height Setting of Bale	24
5. MAINTENANCE AND REPAIR ADJUSTMENT OF MACHINE GUIDE.....	25
5.1. Needle Setting.....	25
5.2. Sente Setting.....	26
5.3. Time Setting	28

5.4. Feeding Fork Setting.....	28
5.5. Needle Saddle Rod Setting	29
5.6. Picking Support Spring Setting.....	29
5.7. Front Picking Lining Setting.....	30
5.8. Front Flywheel Tripod Mount Pressure Plate Setting.....	30
5.9. Horizontal and Vertical Ball Bearing Setting	31
5.10. Piston and Setting of Piston Blades	32
5.11. Safety Latch Setting and Maintenance	32
5.12. Twine Needle Saddle Lining	33
5.13. Maintenance of Shafts	33
5.14. Twine Knotter Group Setting	34
5.15. Winter Care and Storage.....	37
5.16. Needle Packsaddle Rod Setting	38
5.17. Needle Packsaddle Lining	38
5.18. Twine Knotter Setting.....	39
6. TROUBLE SHOOTING.....	40
6.1. Tail Axle Shaft Area	40
6.2. Picker Area	42
6.3. Feeder Area.....	42
6.4. Electrical Circuit Diagram.....	43
6.1. Hydraulic Circuit Diagram	43
7. WIRE MACHINE SETTING GUIDE	44
7.1. Iron Wire Connection	44
7.2. Wire Knotter Group Setting.....	47
7.3. Wire Knotter Needle Saddle Setting.....	48
8. CASES NOT COVERED BY THE GUARANTEE AND SECTIONS	49
9. LIST OF SPARE PARTS	50
10. STARTUP SAFETY PRE-INFORMATION FORM	59
11. THE OPERATION SUITABLE FOR INTENDED USAGE.....	60
11.1. Terms of Guarantee	60
11.2. General Technical Information.....	60

1. GENERAL INFORMATION

1.1. General Description

It is quite difficult to move and stock mown as well as dried grass in the field, clover or the other plants usable as animal feed in the winter, stem or hay of cereals to the storage place. In order to make easier that, abovementioned products are carried by compressing and packing. Thus, straight shaped packets of grass can be stored up easily carrying smoothly without occupying too much place. In this manner, losses that can be during transportation and storing are reduced to minimal. Briefly, we name "baling" to the process of packing and binding of grass, stem of cereals and hay. We call the machines performing this job "Baler Machine".

1.2. Intended Use

Baler Machine is equipped with rectangle baling chamber. Agricultural bale substances like grass and hay are compressed as standard rectangle bales in the bale chamber. Stable bale chamber of Baler Machine can achieve compressing bales in size approximately 36 cm x 46 cm and the size of bales can be changed optionally. Bale makers is equipped with system of knotting. **PITAGORA has two twines or robe system.**

This baler machine has been designed for to be drawn by an agricultural tractor and set in motion by tail axle of tractor. This machine is being used to bale including alfalfa and combined stem/meadow on tilled land for agricultural usage, fodder products turned into barrels.

Baler makers have been designed only for standard agriculture.

Any different usage is not compatible with intended usage. Manufacturer is not responsible for a damage originating from improper, operator's own risk-based usage.

Usable bale substances: These are the grass-typed substances like herb, hay used for animal production. Disclaimer of warranty is not valid in case of usage in excluding purposes apart from this and improper products (such as corn, peanut, cane and bale of chaff).

1.3. General Information

1.3.1. Certification

Quality management system is certified by K-Q TSE-ISO-EN 9001.

1.4. Identification

The serial number of machine is at the right side of drawbar (Figure 2). Vehicle identification number is under of flywheel cover (Figure 1).

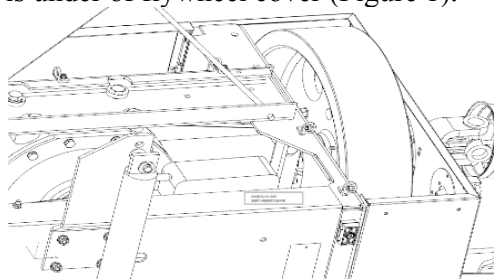

Figure 1: Vehicle Identification Number

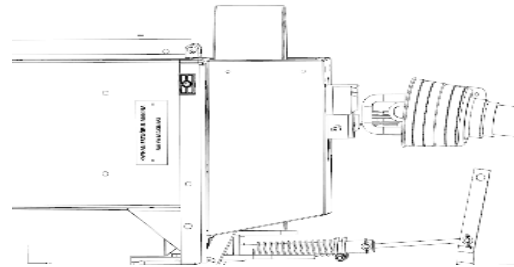

Figure 2: Serial Number of Machine

Every single equipment is equipped with an identification plate (Fig. 1) whose data shows:

1. Mark and address of the Manufacturer;
2. Designation of the machine;
3. Type of machine;
4. Serial number of the machine;
5. Max. unladen mass (kg);
6. Max. laden mass (kg);
7. Production year;
8. EC and EAC marking;
9. "Made in" and QR code;



(9)

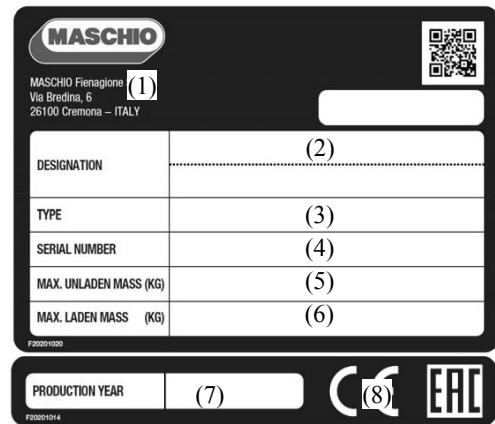

Fig.1

It is advisable to transcribe your data on the serial number below shown on the date of purchase (10) and the name of the dealer (11).

10. _____
11. _____

These data should always be quoted for any need for service or spare parts.



ATTENTION

Do not remove, tamper with or make the CE mark affixed on the machine illegible.

Refer to the information provided on the CE mark for the manufacturer's contact details (e.g. for requesting spare parts, etc.).

When the machine is demolished, destroy the CE marking.

1.4.1. Required Information for Questions and Orders

Please do not forget to add type of machine, machine identifying number and year of production when asking questions or changing parts!

1.4.2. Operation Compatible with Intended Use

Baler makers have been designed only for standard agriculture. Any different usage is not compatible with intended usage.

Usable bale substances: These are the grass-typed substances like herb, hay used for animal production. Disclaimer of warranty is not valid in case of usage in excluding purposes apart from this and improper products (such as corn, peanut, cane and bale of chaff).

1.5. General Factors Regarding Environmental Science

Earth, air and water; indispensable components of agriculture and life generally. If bylaws doesn't get under control or fall short of refining chemical materials to the extent that advanced technology requires; people should have commonsense in using and disposing products derived from chemical and petrochemical materials.

- Earth, air and water; indispensable components of agriculture and life generally. If bylaws doesn't get under control or fall short of refining chemical materials to the extent that advanced technology requires; people should have commonsense in using and disposing products derived from chemical and petrochemical materials.

Some Helpful Hints

- Please avoid to fill the storages by using improper vessels or compressed air systems due to possibilities of pouring in large extents and liquid leakages.
- As a general rule; please prevent all fuel, oil, acid solvents, etc. to touch to your skin. Most of those contain chemical substances that might be harmful to your health.
- Modern oilers contains additive agents. Please do not fire contaminated fuels or/and used oils on traditional heating systems; and do not release to the disposal of requirers on varied purposes.

Useful Suggestions

- Please determine what the relevant legislations are by inquiring.
- If no any legislation about waste management in effect, please get information related to effects of oils, filters, batteries, fuels, antifreezes, cleaning agents, etc... over people and environment and keeping, utilizing and dumping of those materials safely.
- Please avoid dumping of used radiator fluid, oils of engine, transmission and hydraulic, brake fluid and other fluids if any to the environment during pouring. Never mix used brake fluid or fuels with oilers. Please store those safely until you will find an appropriate way of dumping according to legislations or domestic regulations.
- For example, modern radiator fluids as antifreeze and other additive agents must be changed biyearly. Amalgamating of those to soil must not be allowed, instead, those must be accumulated and dumped properly.

2. TECHNICAL INFORMATION

2.1. Tractor Requirements

- Vehicle driving is allowed only if bale chamber is empty.
- Maximum speed allowed: 20 km/h
- For the machines lacking of brake, light weight (tare) of tractor should comply with allowed specifications or at least it has to be comply with tare of bale.
- Please follow specified conditions for machines having operating permission.

Minimum Power Requirement : 45 HP

Tail Shaft Period : 540 1/max.

❖ **Tail shaft period of tractor must not exceed 540 1/max. strictly.**



Please provide each user of the machine to read this User and Service Manual carefully. Keep this booklet by you as a quick reference guide.

2.1. Technical Features of the Baler Machine

Technical Features are showed at Table 2.2.1.

NOTE: Our company reserves the right to change the sizes without informing in advance.

Table 2.2.1: Technical Features of PITAGORA

PITAGORA BALER MACHINE		
CHAMBER OF BALE COMPRESSING		
Compressing Sizes	cm	36 x 46
Piston Stroke	cm	71
Piston Stroke Count (540 p/m)	Stroke/Minute	93
Feeding Window	cm ²	1500
BALE		
Length of Bale	cm	30 - 135
Weight of Grass Bale	kg	71
Productivity	Bale / Day	2000 - 2500
Knotting System		Bow-tie with 2 twines
PICKING LAYOUT		
Width	cm	165
Cam Gaps	mm	70
Picker		5-Arrays Bearing Houses
Number of picker cams	Number	100
FEATURES OF TRANSPORTATION		
Right Wheel		225 / 70 / R15
Left Wheel		10,0 / 80 - 15,3 Tubes 10 PLY
Rear Middle Support Wheel		16,5 x 6,50 - 8 6 PR
Support Wheel		400 x 8 6 PR
Weight	kg	1754
Length (at road position)	cm	505
Length (on duty position)	cm	608
Width	cm	237
Height	cm	182
Minimum Power Requirement	HP	45
Tail Shaft Period	1/min.	540
Transmission		2 Shafts

3. SAFETY

3.1. Determination of Safety Precautions in the User Guide

Before using the machine, this User Manual should be read definitely and safety rules should be obeyed.

It is assumed that customer read all the rules in User Manual of purchased machine.

3.2. Explanations of Safety and Accident Preventer Regulations

Personal Safety

You will notice the warnings on this booklet, machine and stickers followed by specific guidance (“DANGER – TEHLİKE”, “WARNING – UYARI” ve “CAUTION – DİKKAT”). Those warnings are for personal security of both you and personnel working with you. Please allow time to read this warnings.



The word "DANGER – TEHLİKE" indicates a danger situation that might end up with death or severe injury if not prevented. The relevant color linked with danger is red.



The word "WARNING – UYARI" indicates a potential danger situation that might end up with death or severe injury if not prevented. The relevant color linked with warning is orange.



The word "CAUTION – DİKKAT" indicates a potential danger situation that might end up with slight or severe injury if not prevented. The relevant color linked with warning is yellow.

As a result of not to pursue instructions following the words “**DANGER – TEHLİKE**” , “**WARNING – UYARI**” and “**CAUTION – DİKKAT**” might end up with death or severe injury.

3.3. Warnings and Precautions

The best user is, the careful one. Most of the accidents can be prevented by taking significant precautions into consideration. Read the following warnings before using this equipment in order to help to prevent accidents. The equipments should only be used by responsible and trained persons.

Please review process on this User and Service Manual with all the users. It is important for all the users to learn safety warnings and follow them.



Security precautions on this booklet are marked by danger sign which may cause personal injuries in case of not being obeyed.
Explanations attached to the machine should be read, understood exactly and obeyed.

Most of agricultural equipment accidents can be prevented by taking a few safety precautions.

1. Please do not make any purification, lubrication or adjustment on baler machine during it or engine of tractor is working. Find out whether there are rounding parts by listening and observing.
2. Do not enable clutch unless you ensure everyone is away from the machine and no maintenance kit on the machine.
3. Do not work near the baler machine with loose-fitting dress that might squash to moving parts.
4. Do not try to take out hay from any section of baler machine running on.
5. Do not fuel reservoir of tractor that pulling baler machine while its engine is running.
6. Do not use baler machine unless all the bucklers are on the their places.
7. Do not allow anybody to stand over the baler machine.
8. Do not take down connection of baler machine while running.
9. Do not come near to the machine within at least one minute after stop the machine.

3.4. Qualification and Training of Personnel

People using baler machine, maintaining or fixing must be warned against the risks that they might confront during the operation of the machine and should be trained before these. Operator must take the responsibility and watch the personnel. If personnel are lacking of relevant information, at once they should be given required training and explanation. Operator has to ensure that this manual is completely understood by personnel.

Reparation not taking part in this booklet should only be made by the authorised services.

3.5. Failure on Practice of Safety Precautions

As long as not taking safety precautions carefully, there might be personal injuries and environmental dangers as well as damage on the machine. Not to implement safety precautions might lead to ignoring all the claims about damages.

For instance, such dangers may rise in case of not following the safety precautions:

- Risk to people with an error on protection of working area
- Becoming lost of significant features of the machine
- Failure on implementing suggested methods for repair and maintenance
- The risks that may arise due to mechanical and chemical effects.
- Environmental damage that may derive from hydraulic oil leakage

3.6. Secured and Conscious Working

- Please obey safety precautions on this guide, existing accident preventer regulations and any internal works, rules of operation and safety rules determined by operator.
- Accident preventer regulations of responsible professional connections complies with safety.
- Also, safety precautions provided by supplier of vehicle must be observed.
- It is necessary to obey applicable traffic rules on the roads that open to public.

3.7. Safety Precautions and Accident Preventer Regulations

1. Besides safety precautions on this guide, please obey all the applicable de facto safety and accident preventer regulations.
2. For a secured operation, warning and safety marks attached to the machines provide important information. Please pay attention these for your own security!
3. Please be careful to obey the traffic rules on public domains!
4. Be sure to know all the system as well as functions of the machine before working. It is too late to endeavour learning during operating of the machine!
5. Users should wear tight dresses. Please abstain from loose dresses!
6. Leave the dresses clean against to danger of fire.
7. Be sure that nobody is near the machine before running or moving the machine (be careful of children!). Please ensure that you have a wide sight.
8. Passenger transportation, operation and freight transportation are not allowed.
9. Please install devices to the machine properly! Install devices to only specified tool and protect them.
10. Install support tools to accurate places during mounting and demounting devices.
11. Please be very careful while mounting to or demounting from devices tractor!
12. Always install counter balance weights to indicated fixed locations properly.
13. Please observe allowed axle weight, grass weight and sizes of transportation.
14. Install and check transportation equipments such as lighting, warning devices and any protective gear!
15. Initialization mechanism (such as cables, chains, connections etc.) for remote control devices should be regulated so that no movement can set in motion during transportation or in working mode by mistake.
16. Please ensure that devices are in necessary condition for track and close them to indicated place of producer!
17. Never leave driver's seat empty while vehicle is running!
18. Please drive the vehicle on the right speed! Avoid rapid direction changes during driving at ramp, downhill or curved track!
19. Attached tools or driving of ballast weight affects steering wheel and reaction of the machine to brake. Please ensure that you are able to use brake and steering wheel as required.
20. Please consider drifting when rounding the corners and/or radius.
21. Initiate all the devices when all the protective tools put and installed to their proper locations!
22. Always keep working areas of the machine on!
23. Do not be located in the area that device is turning.
24. Operating sections (such as hydraulics, pick-up assembly) by external powers might cause crushing and cutting injuries!
25. Before leaving tractor, ground the devices, turn of the engine and take switch key!
26. Nobody must stay between tractor and baler machine without the safeguard of the vehicle remains top certainly!

3.7.1. Protection of Mechanical Systems

It is necessary to prevent to leave blockage or foreign substance by checking mechanical systems of the machine before and after running.

3.7.2. Processes of Linking Shaft

1. Use only tail shafts specified by producer.
2. Please ensure that shaft protective covers are in their places for tail shafts and un duty position on the working field.
3. Disconnect tail shaft after installing or demounting PTO shafts; turn the device off and eject switch key!
4. When PTO shafts are used with self-exciting couples unprotected by keeper on tractor or excessive weight safety, please hang excessive weight safety or self-exciting couples to section of device.
5. Please ensure that PTO shaft is installed and protected properly.
6. Add chains to inhibit rounding of PTO shaft protector with shaft.
7. Be sure that selected tractor speed of PTO shaft matches with allowed device speed before put on PTO shaft.
8. Feel certain nobody is in danger near the device before adding PTO shaft.
9. Never connect PTO shaft during engine is running.
10. If PTO shaft is running, nobody should be near of circle!
11. Always close down PTO shaft if it is unnecessary or the angle is too wide.
12. **Warning!** Engine flywheel will continue to turn round for a while after disconnection of PTO shaft. During this time, keep equipments clean! Do nothing to equipments till the machine stops completely and engine flywheel is secured by using handbrake!
13. Take off PTO shaft, stop the engine and eject switch key during connecting PTO shaft to driving tools or PTO without cleaning and greasing.
14. Insert disengaged PTO shaft to suggested support bracket.
15. After disengaging PTO shaft, add protective cover end of PTO shaft!
16. In case of any damage, please fix the malfunction at once before using the vehicle again!

3.7.3. Hydraulic System

1. Hydraulic system is compressive, please be careful.
2. Be sure that hydraulic hoses are connected properly when making connection hydraulic cylinders and engines.
3. Be sure that both tractor and vehicle hydraulic are not compressed while connecting hydraulic hoses to tractor hydraulic.
4. Connective muffs and cables should be taken into consideration for making certain a proper connection on hydraulic connections between tractor and vehicle. If connections are reversed, so the functions.
5. Please check hydraulic hoses periodically, change them if they are damaged or get exhausted. New hoses have to meet the basic requirements determined by producer of the vehicle.
6. Use suitable devices for avoiding risk of injuries while seeking leakage!
7. Leaking liquids (hydraulic oil) from high pressure might be harmful to skin and cause some serious injuries! Immediately get medical aid in case of an injury! There can be a risk of infection!

3.7.4. Tyres

1. During working on tires, be sure that vehicle is lowered and protected against to danger of rolling! If it is on sloping place, prevent skidding of the machine by chocking wedge in front of tires on the sloping direction.
2. Mounting tires and wheels requires sufficient information and proper tools.
3. Works of reparation on tires and wheels should be done by specially trained people using proper installation devices.
4. Please control pressures of tires periodically, set the suggested pressure for them!

3.7.5. Maintenance

1. Be sure that engine and energy are off before any reparation, maintenance or cleaning!
 - Take off the switch key. Eject key of engine from contact and take along.
 - Take engine flywheel with hand braking.
2. Periodically check whether bolts and belts properly, screw if necessary.
3. During maintaining care to a tool at high, always take required precautions against danger of falling!
4. Use always proper gloves and tools while changing devices running with sharp edges!
5. Please dump oils, greases and filters according to regulations!
6. Always disconnect energiser before operating electrical system!
7. If protective devices and safeguards get eroded, check them regularly and alter with new ones timely.
8. By electrical welding to tractor and added tools, take alternator and cables of battery off!
9. Renewed sections should meet technical requirements marked by producer. This can only be done with actual spare parts of Maschio Fienagione

3.8. Unauthorised Modification and Producing Modified Parts

Modifications that will be made on the machine are only allowed with producer's approval. Genuine spare parts and supplement units supplied by producer ensure a safe usage.

3.9. Prohibited Forms of Operating

Machine's operation safety is valid only when it is utilized in accord with intended use in the section of General Information in the guide. Limiting values written in data tables should be never exceeded.

3.10. Introduction to the Machine

Maschio Fienagione baler machine is equipped with all required safety tools. However, since the protectives and equipments will harm to functions and abilities of the machine, it is impossible to remove all potential dangers.

Convenient danger warnings on the machine advises against any danger!

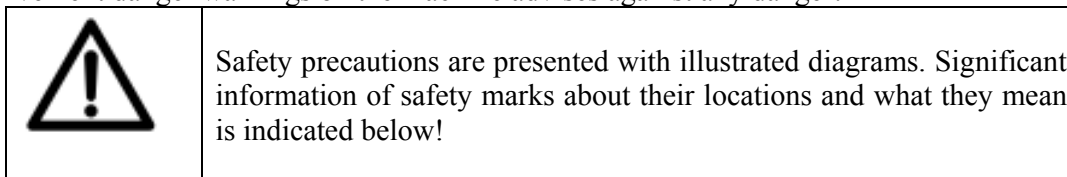

3.11. Safety Warnings on the Machine

1. Pay attention, do not run machine without reading user guide.
2. Pay attention, while making reparation and maintenance; stop the tractor, turn the switch off and eject switch key.
3. Danger of being crushed; do not get into between tractor and machine while baler machine is running.
4. Pay attention; pick-up system might seize during the running of baler machine, keep away from it.
5. Pay attention; do not open safeguards of chains and gears while machine is running.
6. Pay attention; it may seize, do not take off and open safeguards of the machine.
7. Warning, Danger of cutting: Machine may seize your hands from a distance while running. Do not open safeguards and take off protectives.
8. Do not wait while machine is running near of it.
9. Cycle of tail shaft and direction of rotation.

Figure 3.11.1: Safety Warnings on the Machine

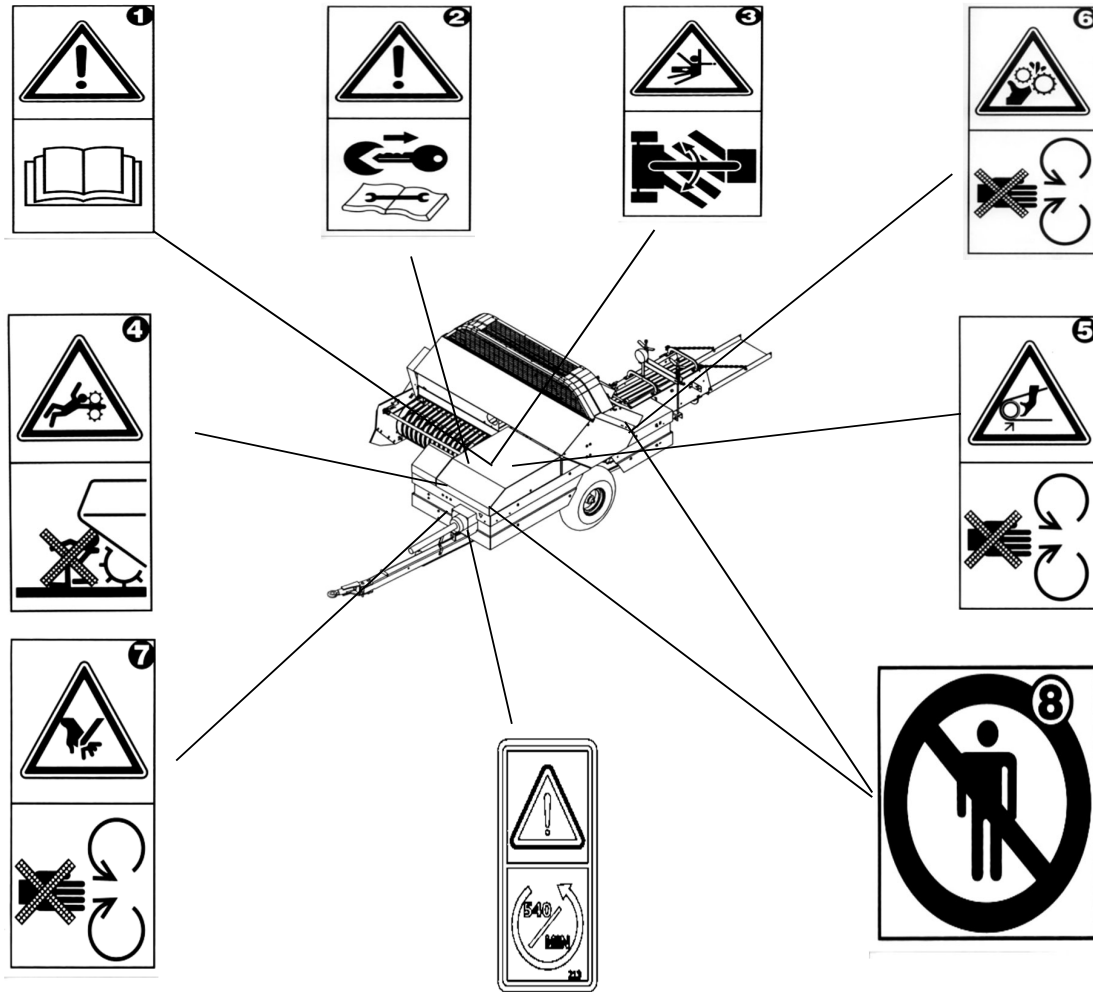

3.12. Danger Area

Do not come closer to the machine more than distances indicated below Figure 3.12.1 while machine is running. Otherwise, you may cause serious working accidents.

Figure 3.12.1: Measurements of Danger Area

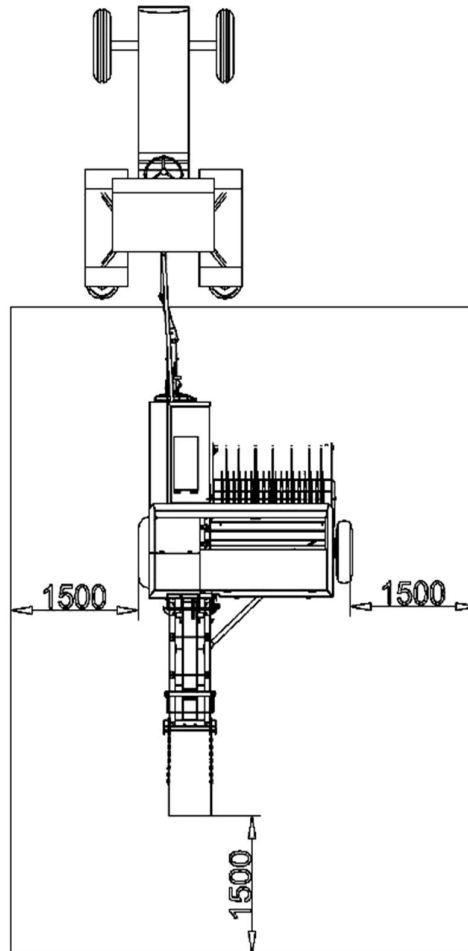

4. INSTRUCTIONS OF MACHINE OPERATING

4.1. Leading Operation

Before operating, baler machine should be completely assembled and connected to tractor.

If a different traction vehicle is used, those below are to be checked, adjusted and connected if necessary:

- Height of drawbolt
- Length of PTO shaft

Specific Safety Precautions

The other specific safety precautions are necessary for the baler machine as well as general safety precautions.

	<p>General safety precautions are in use for all the maintenance, pick-up, reparation and knotting:</p> <ul style="list-style-type: none"> • Immobilise the machine completely. • Switch off the engine. • Eject the switch key. • Protect tractor and baler machine against to danger of tumbling. If track is sloped, chock the wedge in front of tires on the side of slope. <p>During operating, keep a proper spacing compatible with all pieces in motion of baler machine. This is especially valid for pick-up tool. Take off cables only when PTO is off and engine is immobile.</p> <p>Turn engine off, eject switch key and disconnect 12 V supply!</p> <p>In case of dangerous cases, immediately turn off PTO and immobilise baler machine.</p> <p>Never permit running of baler machine if nobody is in tractor!</p> <p>The baler machine can be operated at the speed of 540 r.p.m PTO.</p>
---	--

4.1. Connecting of Tractor to Drawbar

Drawbar should be connected using proper pin. The diameter of coupling pin that will be used should be short 4 mm (maximum) than the hole. After making connection of drawbar, safety pin must be installed (Figure 4).



Figure 3: Draw Bar Coupling

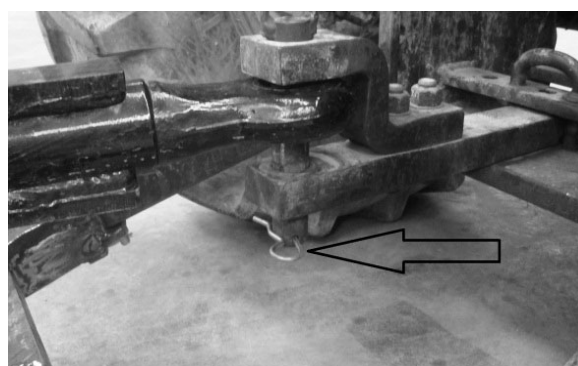

Figure 4: Draw Bar Pin Coupling

4.2. Connecting and Disconnecting Jack System

Jack on the drawbar is disengaged by turning counter-clockwise after the machine is connected to tractor (Figure 5). Set the jack in horizontal position by removing safety pin (Figure 6), Re-connecting safety pin, it is set to road position (Figure 7).



Figure 5: Lifting Jack



Figure 6: Setting jack to horizontal position



Figure 7: Jack safety pin

4.3. Setting The Machine from Road Position to On Duty Position

Firstly, chock a wedge on the right wheel (Figure 8). Pin is removed from its housing by pulling the crank keeping safety pin mounted on the road position to backwards (Figure 9). It is provided safety pin to couple housing in the on duty position by going back and forth.

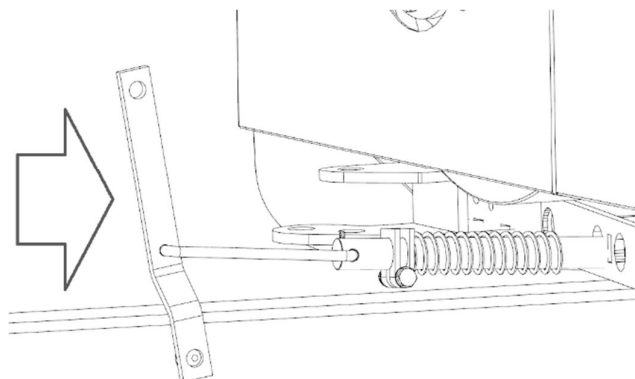

Figure 8: Machine on the road position

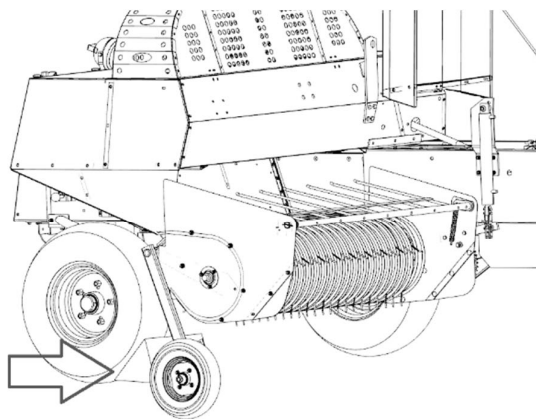

Figure 9: Taking safety pin off on the road position

4.4. Mounting of Shaft

During the connection of shaft, engine must be stopped and key of the machine is to be taken off.

1-) At first, fixed shaft is coupled to the machine (Figure 10). While mounting shafts, locking pins are pulled back (Figure 11). After mounting, locking pins are released and ensured to be fitted into place (a sound of click must be heard after mounting).



Figure 10: Connecting fixed shaft to the machine



Figure 11: Locking Pins of fixed shaft

2-) Connecting of fixed shaft to tractor (attention should be paid on locking pin to be fitted)



Figure 12: Connecting fixed shaft to tractor

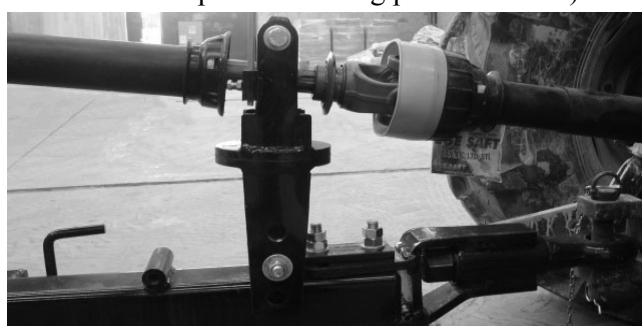

Figure 13: Middle Hanger

In case of shaft middle hanger is not in the proper position, position of drawbar should be fixed appropriately. Otherwise, crashes occur during operation on shaft and middle hanger.

4.5. Fixing of Shaft Guards

After connections of shafts, shaft safeguard chains should be installed to proper places (Figure 14).

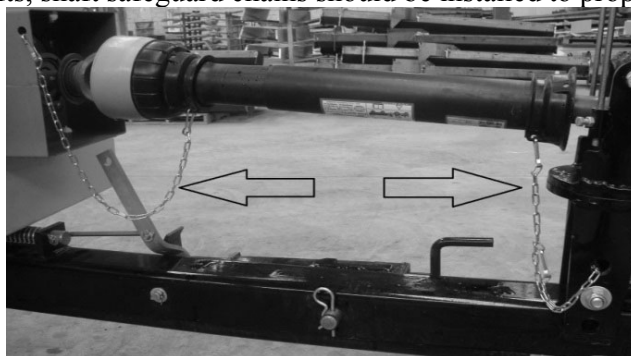

Figure 14: Fixing of shaft safeguards

4.6. Connection of Hydraulic Hoses

Male coupling of hydraulic hoses are connected to female couplings of tractor by taking off housing on the machine. During removing, clamp on female coupling is removed pushing forward. While mounting, it is ensured to fit into housing by pushing forward (Figure 15).



Figure 15: Connection of Hydraulic Hoses to Tractor

4.7. Connection of Electrical System

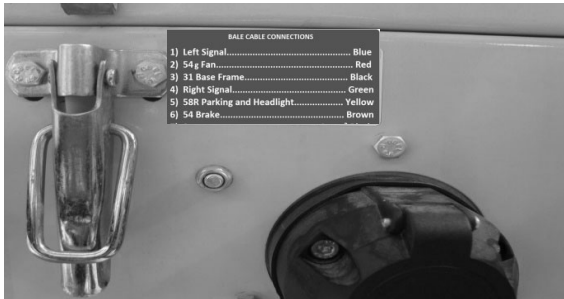

Figure 16: Power connection outlet



Figure 17: Electric connection cable

Plug-in tip of electrical connection given as spare part is installed to the machine. The other tip is connected to tractor according to Connection Diagram by authorised service in the direction of instructions.

4.8. Connection of Twines to the Machine Accurately

Twines are placed into twine chamber without melding, afterwards they thread from tension springs to the needles by reeving twine tightening tool. Twines are connected to attachment point at the first connection.

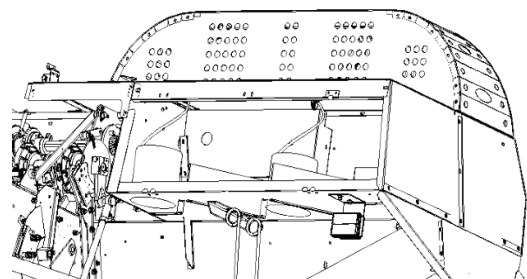

Figure 18

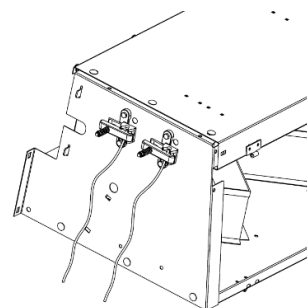

Figure 19

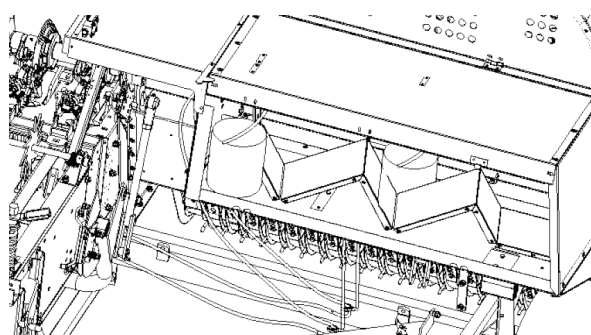

Figure 20

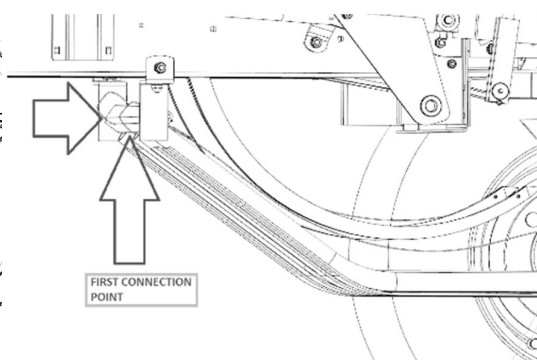

Figure 21

4.9. Adjusting of Support Wheels

Support wheel is set as 22-25 cm from the ground on a flat area (Figure 22).

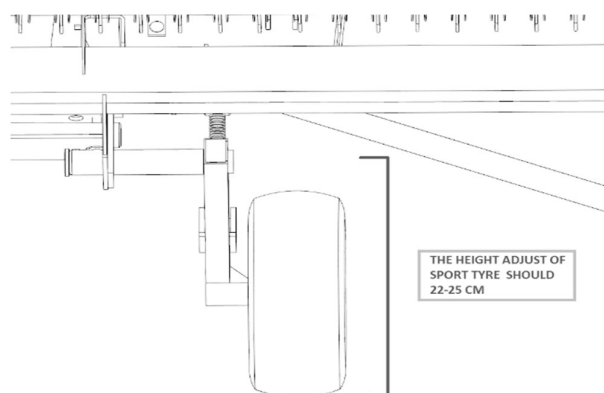

Figure 22: Support Wheel

4.10. Opening of Rear Hatch

The hatch which bales exit from should be opened parallelly to the floor.

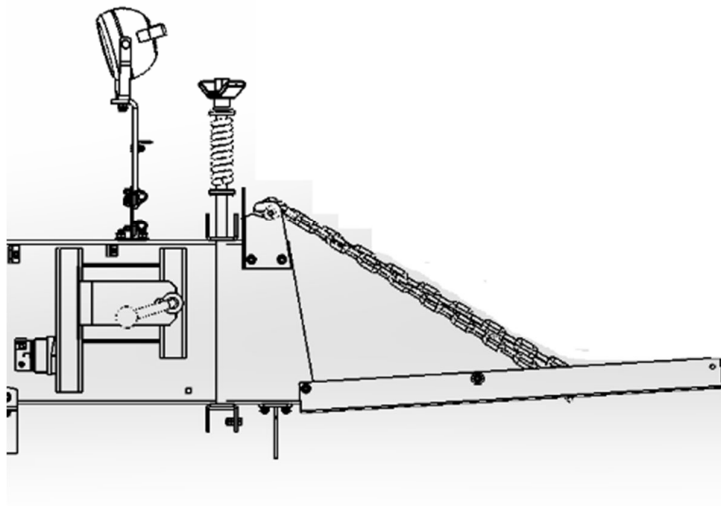

Figure 23: Bale Outlet Hatch

4.11. Support Adjustment of Picking Gear

Pick up spring height should be adjusted as 5 cm (Figure 24). Afterwards, support wheel is set according to pick up spring height (Figure 26).

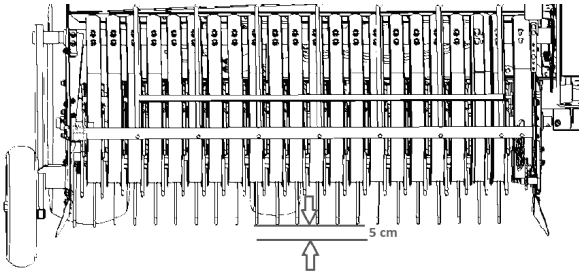

Figure 24: Pick up Spring Height

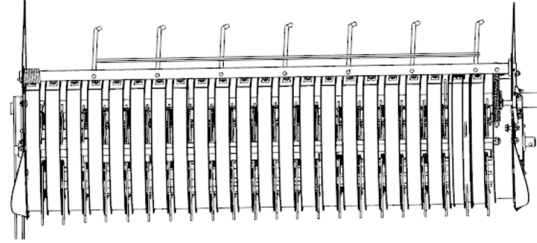

Figure 25: Pick up system

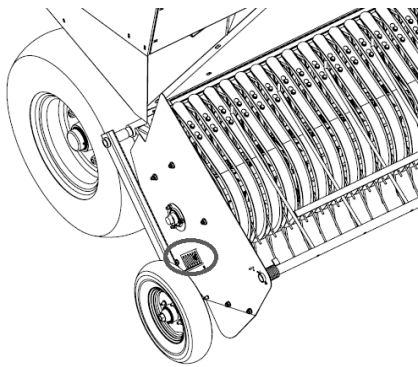

Figure 26: Support wheel adjustment bolt

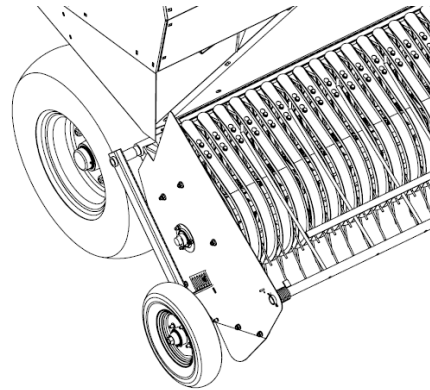

Figure 27: Pick up support wheel

4.12. Form, Weight and Height Setting of Bale

After producing first bale, length of fourth bale is measured and weight of it is checked for adjustment of weight and length. If length and weight are not on preferred quantity, once again length and weight of bale are measured on eighth bale. **Note: This adjustments will change according to field, so settings of weight and length should be arranged once more again.**

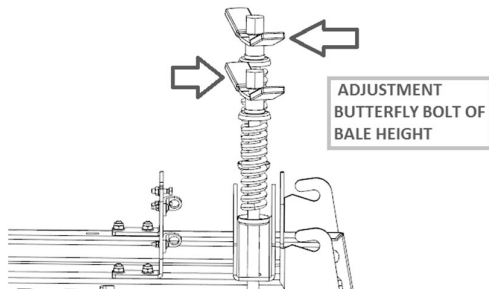

Figure 28: Bale Height Adjustment Butterfly Bolts

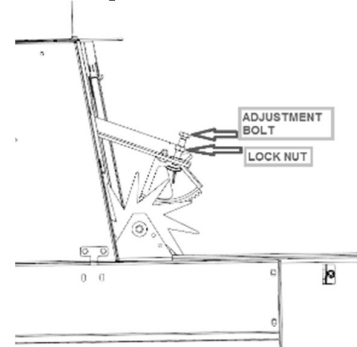

Figure 29: Bale length adjustment bolt

Bale shape adjustment is configured with adjusting bolt according to shape of bale by unscrewing of locking bolt and rounding right or left as seen in Figure 30.

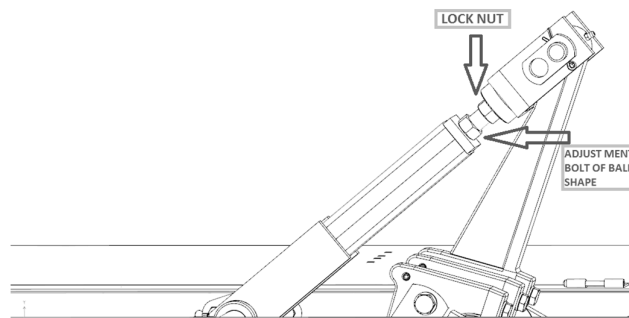

Figure 30: Bale Shape Adjustment

- Bolts, nuts, shims on sections and parts of the machine might be unscrewed during passing hilly and stony roads when the machine is connected to tractor with maximum highest speed. In this case, damages and malfunctions can be occurred during the running of machine. Required solution is to screw bolts and nuts by checking at every workday.

5. MAINTENANCE AND REPAIR ADJUSTMENT OF MACHINE GUIDE

5.1. Needle Setting

Locking bolts are screwed (Figure 31). Lockings of adjusting bolts are unscrewed (Figure 32). After those processes, needle is set to knotting position (Figure 33) and spacings of needle adjusting bolts, top part of it and hook gear are set to be 1-2 mm (Figure 34).

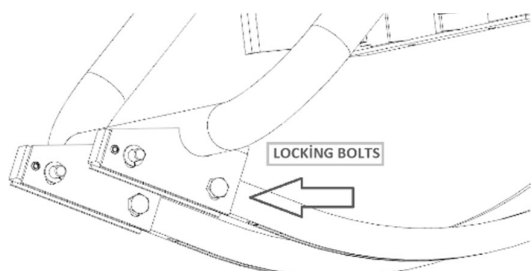

Figure 31: Locking Bolts

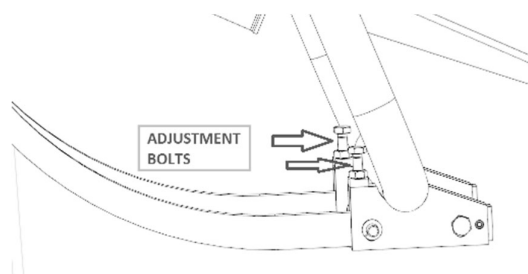

Figure 32: Adjustment Bolts

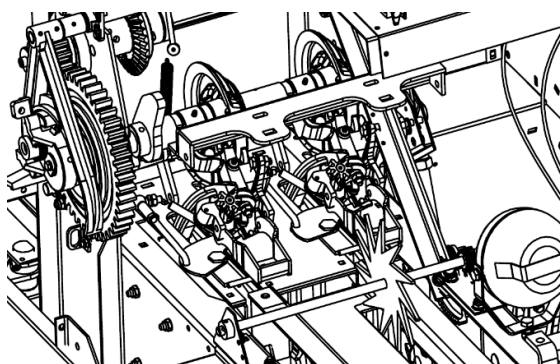

Figure 33: Position of knotting

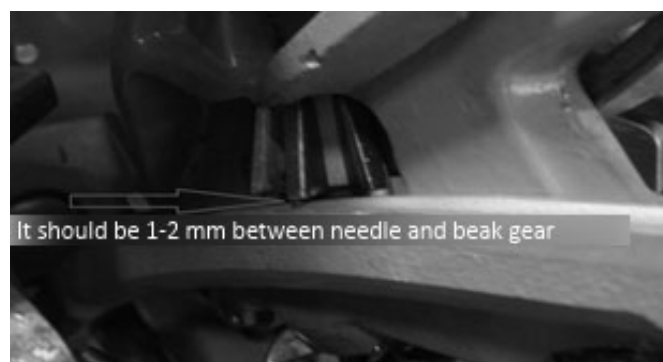

Figure 34: Needle setting

5.2. Sente Setting

- Wrapped pins of knotting groups motion disk must be removed (Figure 35).
- Take off automatic latch of locking setscrew and front bolt (Figure 36).
- Actuating latch and cotter are removed (Figure 37).
- Grand gear is removed (Figure 38).
- Position of piston is set by rounding of flywheel to the working direction (Figure 39).
- Needles are set to the position (in Figure 40) by pushing needle saddle.
- Cotter, actuating latch are installed by levelling together.
- **NOTE: Centre adjustment must be tested before the machine is running necessarily.**

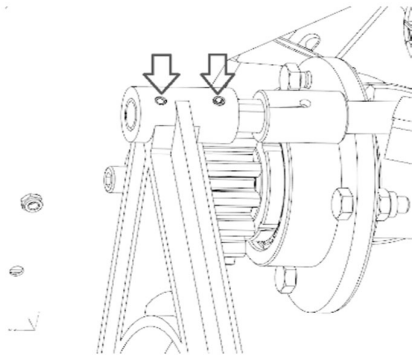

Figure 35: Wrapped Pins

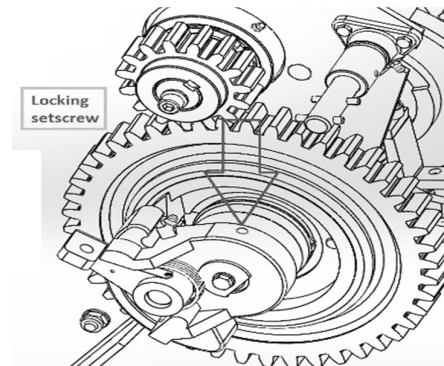

Figure 36: Locking setscrew

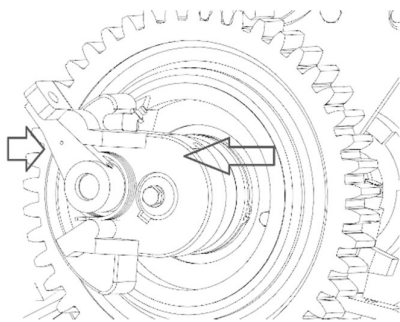

Figure 37: Actuating latch and scissors

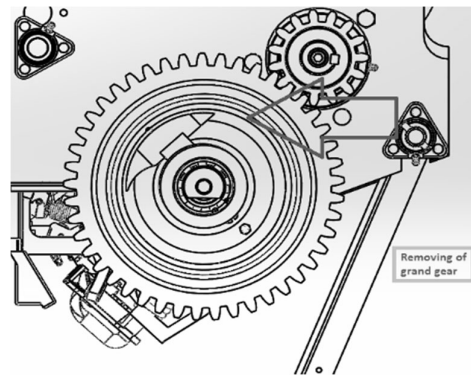

Figure 38: Removing of grand gear

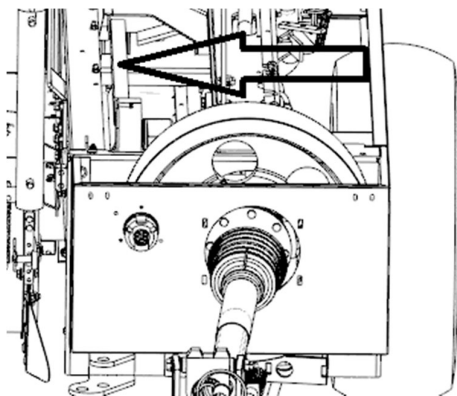

Figure 39: Working Direction of Flywheel

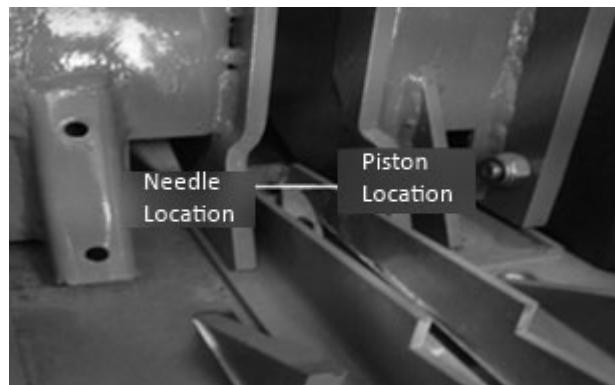

Figure 40: Location of needle

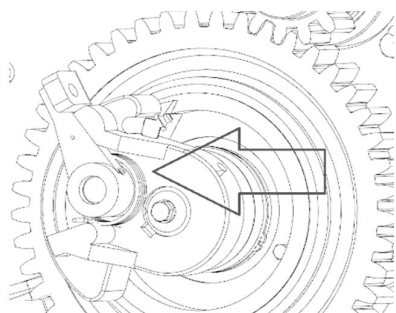

Figure 41: Actuating latch

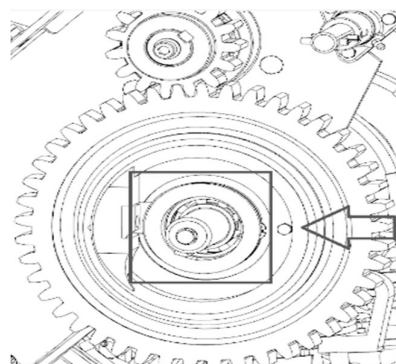

Figure 42: Adjustment Raynel and chock

5.3. Time Setting

- Shaft is removed by locking bolt is taken off (Figure 43)
- Piston rod is set to vertical position (Figure 44).
- Front hayfork crank must be 5 or 6 cm from its corner to safeguard (Figure 45) .
- Upper pot pin centre of knotting system must be at 31 cm range to lower chassis (This adjustment as spacing should be 26,5-27,5 cm on wired machines, not go down below 26,5 cm absolutely.) (Figure 46)
- After adjustments are completed, shaft is fixed with locking bolt and installed.

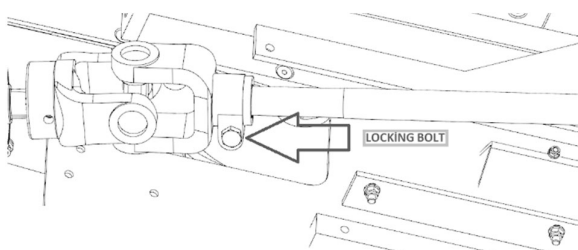

Figure 43 Locking Screw

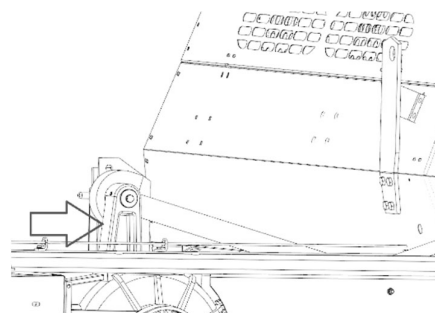

Figure 44: Piston Rod

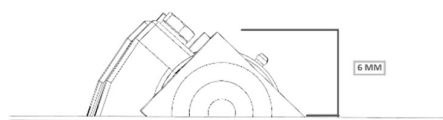

Figure 45: Crank of Front Hayfork

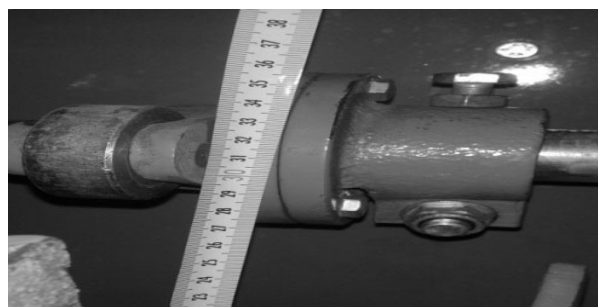

Figure 46: Wedge Pin

5.4. Feeding Fork Setting

- Chain tensioner sprocket is separated from chain lock by unscrewing (Figure 47).
- Spacing between hayfork lamas are set to be 9-10 cm and chain is fastened (Figure 48). Later, chain is tightened by chain tensioner sprocket.

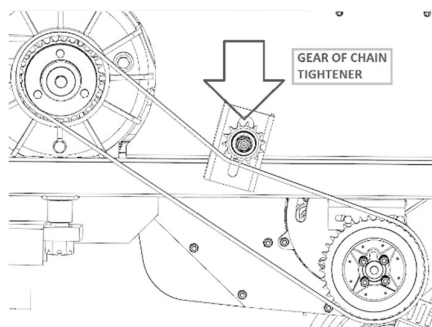

Figure 48: Spacing between lama tips

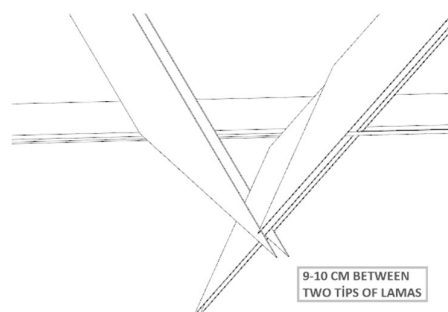

Figure 47: Chain tensioner sprocket

5.5. Needle Saddle Rod Setting

Locking nut of needle saddle rod is unscrewed. Pin under the rod of needle saddle is removed, locking nut is turned and intermediate spacing is provided to be 525 mm, hereby the adjustment is set (Figure 49).

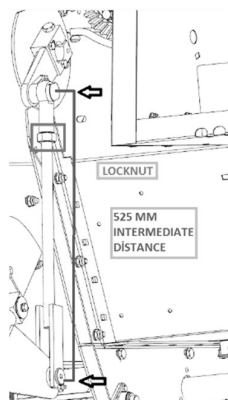

Figure 49: Adjustment of needle saddle rod

NOTE: It must be tested after this process.

5.6. Picking Support Spring Setting

While front pick up unit is above, spring tension should be adjusted. Wrap gap of springs are to be 1 mm (Figure 50, Figure 51).



Figure 50: Pick up support springs

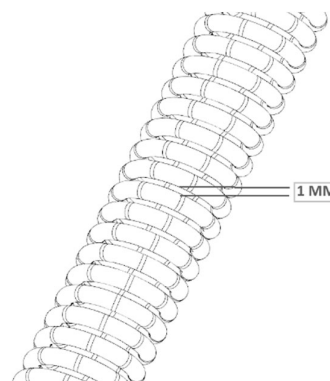

Figure 51: Pick up support spring

NOTE: Machine is running bumpy if wrap gaps are longer than 1 mm.

5.7. Front Picking Lining Setting

After approximately 10.000 bales using of the machine, adjustment (screwing of springs) is required according to deformation of pressure lining springs. Pressure spring spacing must be 3 mm when new lining is mounted (Figure 52).

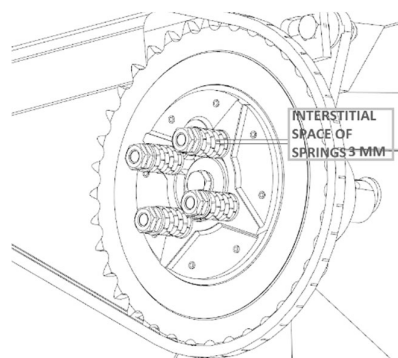

Figure 52: Lining of front

5.8. Front Flywheel Tripod Mount Pressure Plate Setting

After approximately 10.000 bales using of the machine, adjustment (screwing of springs) is required according to deformation of pressure lining springs. Pressure spring gap must be 3 mm when new lining is mounted (Figure 53).

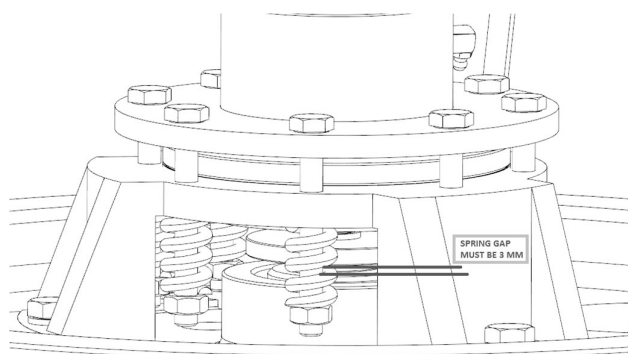

Figure 53: Tripod Pressure

5.9. Horizontal and Vertical Ball Bearing Setting

Gaps of horizontal and vertical bearings must be adjusted as 0,5 mm – 1 mm spacing between bearings and bearing housings. After this settings has been adjusted, comfortable working status is set by turning of flywheel with hand.

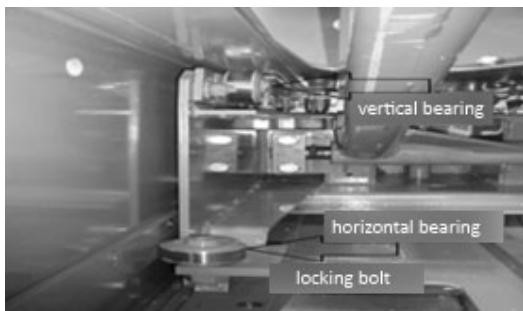

Figure 54: Vertical and horizontal bearing

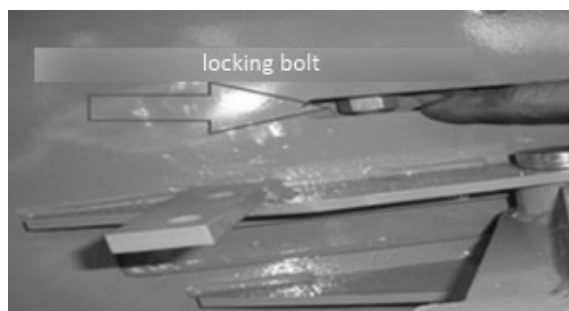

Figure 55: Locking bolt

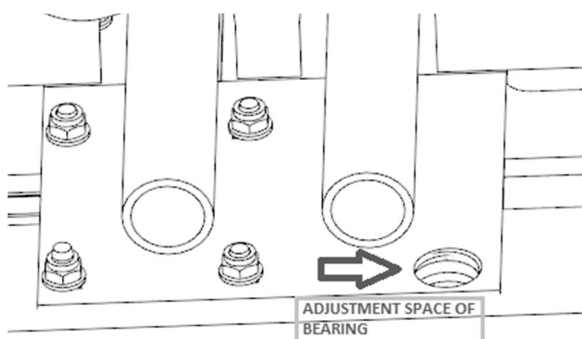

Figure 56: Bearing Adjustment Space

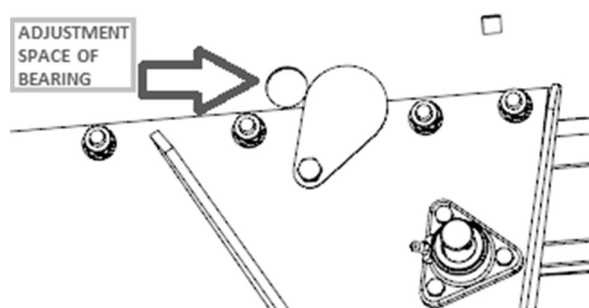

Figure 57: Bearing Adjustment Space

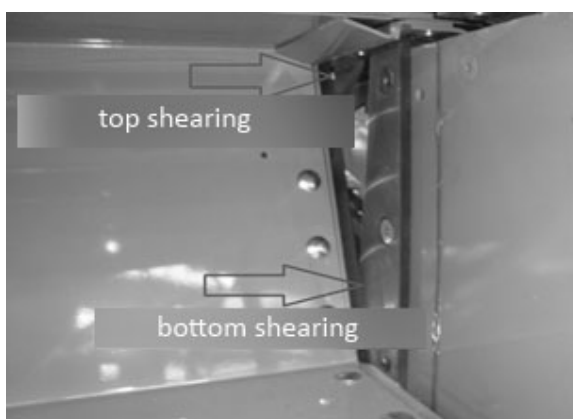

Figure 58: Top and bottom shearing

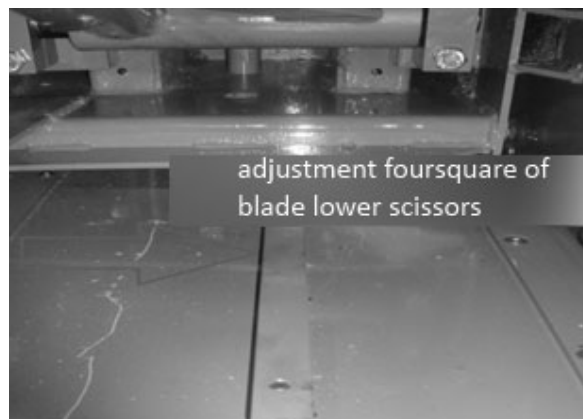

Figure 59: Blade lower scissors adjustment lama

5.10. Piston and Setting of Piston Blades

Upside and underside should be adjusted separately while setting the shearing layout gap adjustment between piston blade and stable blade. If the layout of shearing cutting is out of order, it is required to be set piston cradle adjustment bolts. Blade underside gap adjustment is to be set square tune.

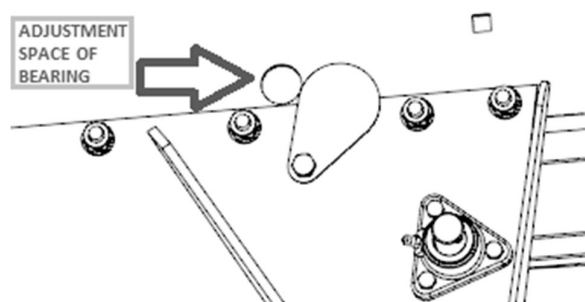

Figure 60: Bearing Adjustment Space

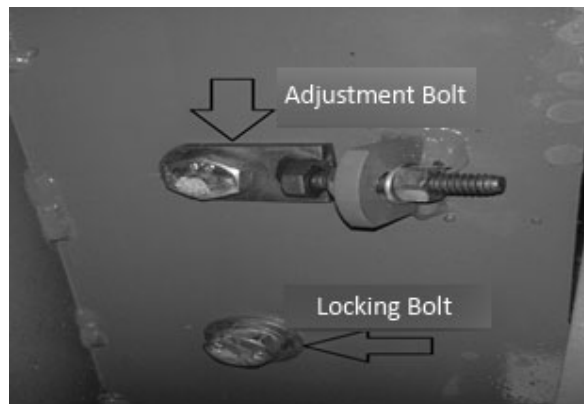

Figure 61: Adjustment and Locking Bolt

5.11. Safety Latch Setting and Maintenance

Arising substances during working such as dust, oil, stem, straw etc. might cause malfunction on needle safety system and it does not work. Needle and linking systems may be damaged in such circumstances. It is paid attention that safety latch pin is removed, carrying out maintenance and the system will be in working order. If triangle of gauge is laid backwards, adjustment bolts are unscrewed, triangle of gauge set towards to latch and bolts are screwed. Whether safety latch system is working should be check exactly in daily maintenances (Figure 62).



Figure 62: Safety latch

5.12. Twine Needle Saddle Lining

Adjustment bolts used in adjustment of needle saddle lining should be set as 3 mm from nut (Figure 63).

Note: Knotting group linings should be recalibrated with respect to abrasion rate of lining bolts after 10.000 bales.

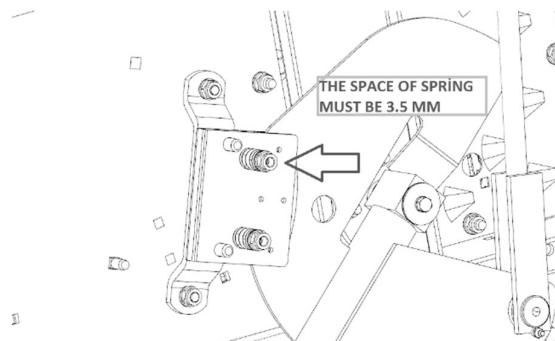

Figure 63: Lining of needle saddle

5.13. Maintenance of Shafts

Shaft joints and clutches must be greased daily from grease nipple. Shafts must certainly be used with guards. Guard should be blocked to turn with shaft by fixing guard chains. Shaft and guard being deformed must be replaced with new ones (Figure 64).

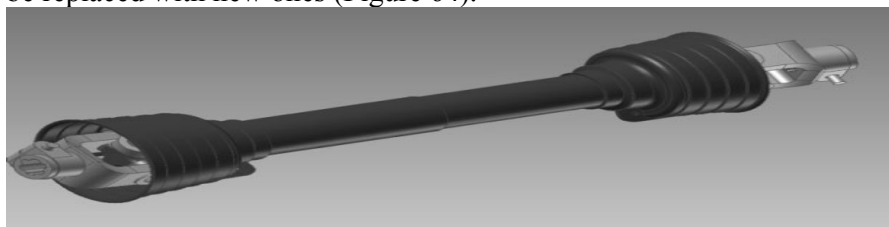

Figure 64: Shaft

5.14. Twine Knotter Group Setting

Trying section adjustment and nuts should be set according to Troubleshooting at the table 5.14.1. Problems are to be solved utilising the same table in twine diverter mechanism. Knotting section adjustments are showed below in the pictures.



Figure 65: Spacing between forks

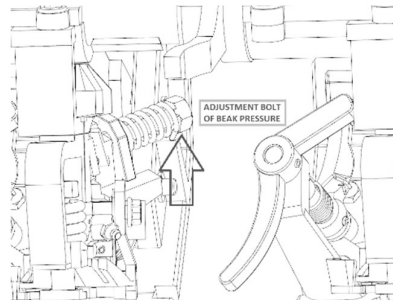

Figure 66: Hook-type Pressure Adjustment Bolt

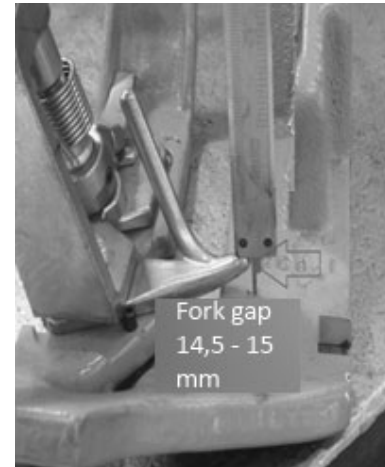
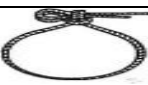











Figure 67: Star-type Pressure Adjustment Bolt

Table 5.14.1 Troubleshooting of Knotting Group

MALFUNCTION		SOLUTION
	Loose knot, not tightened from well cut tips.	1) Hook pressure bolt is screwed with half round spaces until error is corrected.
	Twine's hanged position to the hook breaking before catch hook.	1) Spacing of star increased. Star gear is checked and changed if necessary. 2) Star fixing shim is turned. Please straighten the fixing shim.
	In case of long part breaks as if it displaces though knot is solid.	1) The spacing between needle and knotting group log is increased during on duty position. The spacing between needles and knotting group logs is observed while drive lever of knotting group at the top dead center. Needles have been set to declutch, stretching according to spacing and providing friction with knotting group log.
	Knot is on the side of short part.	1) Star-type press misses the twine (spring of star-type press is screwed with half round spaces until the error is corrected).
	If the knot is tied on the short side (the tip of breaking twine is under the panel twine tied).	1) Star-type press is too tight. Spring of star-type press is unscrewed with half round spaces until the error is corrected). 2) Twine error. Twines are changed.
	If the twine digresses from canal of pressure as knotless;	1) Hook mile is broken. Please change the Hook mile. 2) The lock-catch on knotting group log of Hook pulley had been deformed or displaced. The lock-catch should be changed.
	In case of a strangulation on the long tip, the long part of twine is knotted.	1) Dilation on the twine diverter drive lever. Please adjust space setting between the space twine diverter and fork from the twine diverter drive lever.
	If the twine is broken next knotting location;	1) The spacing between hook and fork gets tightened, sharp line on the tip of fork occurred. Sharped line is ground via sandpaper or needle and adjustment of fork is made with Hook. 2) Fork pin is broken, fork is not on the position that it has to be. Fork pin is changed, fork adjustment is re-adjusted with Hook.

	<p>Twine brought by needle is not knotted if knotless part of the twine is on the side of tractor above bale.</p>	<ol style="list-style-type: none">1) Needle adjustments are disordered, please make the needle adjustment.2) Twine diverter fork adjustments are broken. Please make the adjustments of twine diverter and fork.
---	---	---

5.15. Winter Care and Storage

	<ul style="list-style-type: none"> • The machine must stand firm for the processes such as care, cleaning or repair; engine of tractor must be stopped. 12V electrical supply cable must be taken out. • Please reassemble all the protective parts if removed, after the maintenance. • Avoid contact of used greases during maintenance with skin. • Please go to the nearest hospital in case of an injury by hydraulic grease.
---	--

Clean inner and outer sections of baler machine entirely before placing it for winter storage. Do not direct water jet to axle spots if using high-pressure cleaner. Grease all the points of lubrication after cleaning of the machine. Do not clean greases leaking out of housings. This grease mud provides an extra protection against to moisture. Take off driving chains and clean with crude oil (do not use another solvent). Also, check the abrasions of chains and chain wheel. Grease chains after cleaning.

Please check all the moving parts (such as gears and stretch forming parts) whether they can move easily. If necessary; remove and clean, and mount after re-grease. If necessary change with another one.

Please use only original spare parts of Maschio Fienagione.

Disintegrate PTO tail axle if needed. Grease inner and protective tubes. Grease oiling nipple on cardan joint and bearing rings on protective tubes. Please keep baler machine in a dry place, away from fertiliser and stables. Please restore damaged colours, cover uncoloured sections with anticorrosion substance.

	<p>Use suitable jack stand. Please be sure that the machine stands in a secure position.</p>
--	---

Lift the baler machine with jack for preventing damage to tires (damage might occur on tires if baler machine stands on the same position for long time). Protect tires against to external effects (such as oil, grease, direct sunlight).

Please complete required reparation after harvest season. Prepare a list of all the essential spare parts. By such a systematic operation, work of Maschio Fienagione's service easier and you will ensure that your machine can be operated at the best in the beginning of the new season.

The machine must be preserved supporting the tires on the wedge in a dry and upper closed place.

5.16. Needle Packsaddle Rod Setting

The length of needle packsaddle rod should be adjusted as 515 mm (Figure 68).

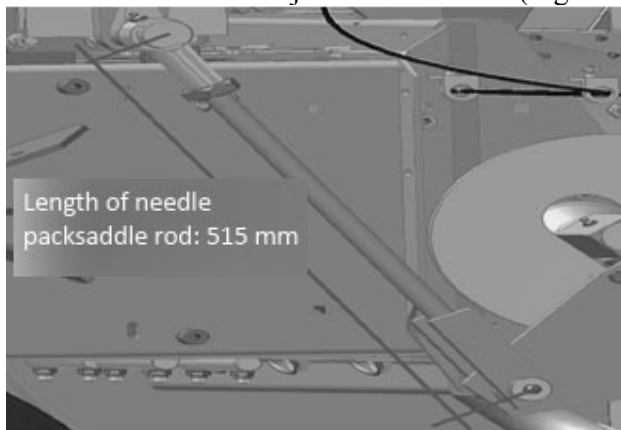

Figure 68: Adjustment of Needle Packsaddle Rod

5.17. Needle Packsaddle Lining

Adjustment bolts used in adjustment of needle packsaddle lining should be set as 3 mm from nut. Spaces of bolts in Knotting Group Lining are to be adjusted as 5 mm.

Note: Tying group linings should be recalibrated with respect to abrasion rate of lining bolts after 10.000 bales.

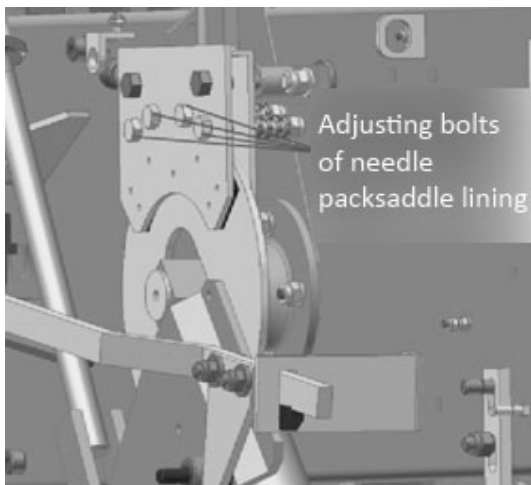

Figure 69: Lining of Knotting Set

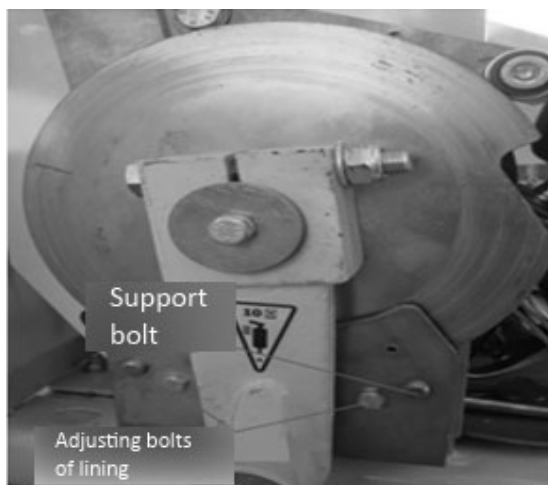

Figure 70: Lining of Needle Packsaddle

5.18. Twine Knotter Setting



Figure 71: Adjusting Bolt of Star Press

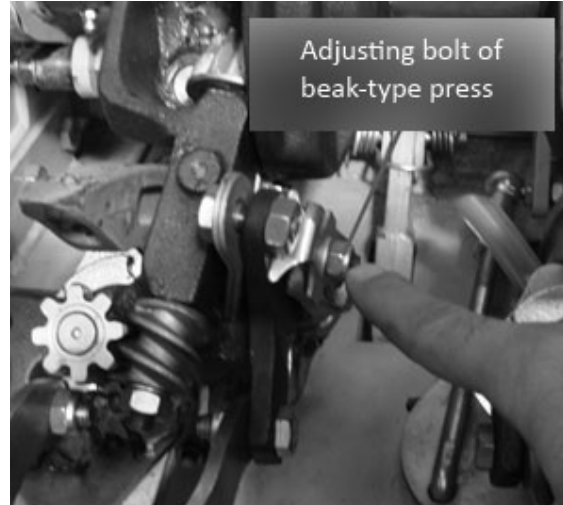

Figure 72: Adjusting Bolt of Beak Press

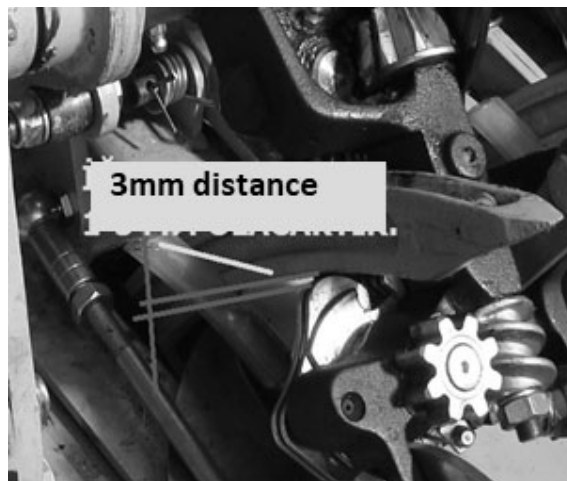
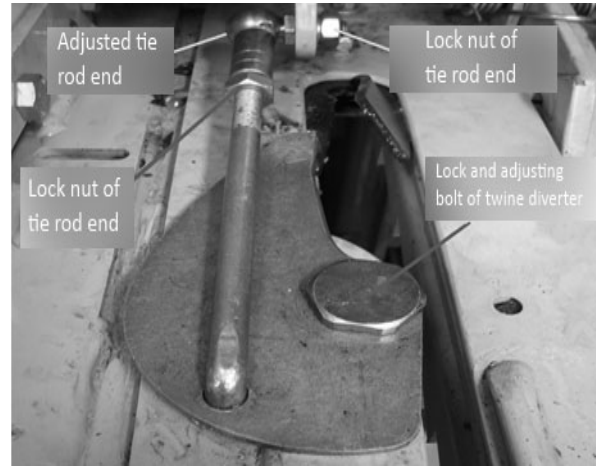
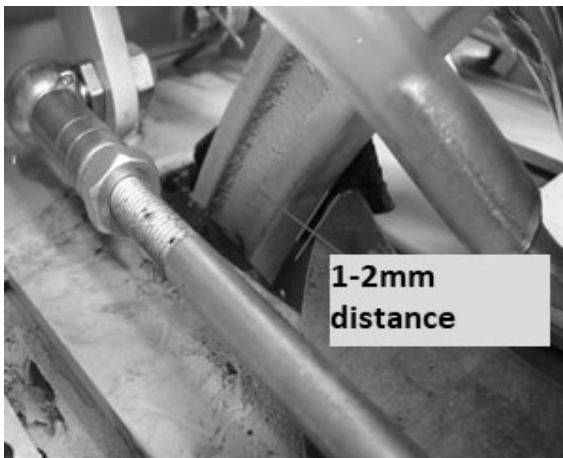

Figure 73: Section of Twine Deviator

6. TROUBLE SHOOTING

Probable malfunctions and troubleshootings of Baler Machine are shown below.

6.1. Tail Axle Shaft Area

The problems and solutions related to Tail Axle Shaft Area are shown in Table 6.1.1.

Table 6.1.1 Tail Axle Shaft Field: Problems and Solutions

PROBLEM	PROBABLE CAUSE	SOLUTION
1) Universal Joint Malfunction	1.1) Over loading 1.2) Enabling of clutch of tail axle causes shock loading since cycle of tractor tail axle is over. 1.3) Short turnings causes joints to come down. 1.4) Wheels of tractor strike with tail axle transmission shaft while turning. 1.5) Draw's length, height or alignment is wrong. 1.6) Joint of power transmission or position of roller bearing is wrong. 1.7) Greasing is insufficient.	1.1) Please check safety clutch of tail axle shaft. Adjust according to specifications on this user and maintenance guide. 1.2) Please activate tractor tail axle on idling. 1.3) Please deactivate tail axle during short turnings. 1.4) Turn wider. 1.5) Please adjust drawbar and position of tail axle. 1.6) Adjust according to specifications on this user and maintenance guide. 1.7) Grease at every 50 hours.
2) Shaft is bent	2.1) Tractor tail axle has been enabled when engine speed is over of idling. 2.2) Tail axle shaft clutch is too tight or frozen.	2.1) Enable tractor tail axle on idling. 2.2) Please check the clutch.
3) Vibration (especially) during turnings	3. 1) Universal joints are not adjusted. 3.2) Power joint or roller bearing is not adjusted properly. 3.3) Tractor drawbar' length, height or alignment. Abraded extended or shortened sections.	3.1) Change the defected part. 3.2) Adjust drawbar according to proper specialties. 3.3) Change as required.

PROBLEM	PROBABLE CAUSE	SOLUTION
4) The clutch of tail axle shaft gets out of clutch pilot shaft.	4.1) Torc of fixing bolt is wrong or only one hardened shim is used under the bolt. 4.2) Incorrect dimensional shim(s) under the bolt head. 4.3) Incorrect adjusting shim is mounted on the hub of inaction clutch. 4.4) Fixing bolt is screwed excessively or defected partially during montage. 4.5) Greasing is insufficient.	4.1) Please mount accurate equipment with accurate torc. 4.2) Please mount accurate hardened shims. 4.3) Flywheel should be rounded freely while tractor tail axle is disabled and tail axle shaft is stopped. 4.4) Disassemble adjusting shims as required. Change the equipments and screw with accurate torc. 4.5) Grease at every 100 hours.
5) Clutch complex gets out of flywheel	5.1) There is dye between clutch and flywheel. 5.2) The clutch of tail axle shaft is too tight or cohered. 5.3) Enabling of tractor tail axle causes shock charges while engine speed is at high level.	5.1) Erase the dye. 5.2) Please check clutch of tail axle shaft and adjust. 5.3) Enable tractor tail axle on idling.

6.2. Picker Area

The problems and solutions related to picker area are shown in Table 6.2.1.

Table 6.2.1 Picker area: Problems and Solutions

PROBLEM	PROBABLE CAUSE	SOLUTION
1) Barrel is not picked up cleanly.	1.1) Picking spring is lacking. 1.2) Speed of advance is too high. 1.3) Picker lining misses holding.	1.1) Complete picking springs. 1.2) Lower the speed of advance. 1.3) Check the lining adjustment.

6.3. Feeder Area

The problems and solutions related to feeder area are shown in Table 6.3.1.

Table 6.3.1 Feeder Area: Problems and Solutions

PROBLEM	PROBABLE CAUSE	SOLUTION
1) Form of bale is bad.	1.1) Hayfork adjustment is defected. 1.2) Speed of advance is wrong.	1.1) Make the adjustment of hayfork. 1.2) Adjust the speed of advance for providing proper feeding.

6.4. Electrical Circuit Diagram

The electrical diagram of is shown at Table 6.4.1.

Table 6.4.1. Electrical Diagram

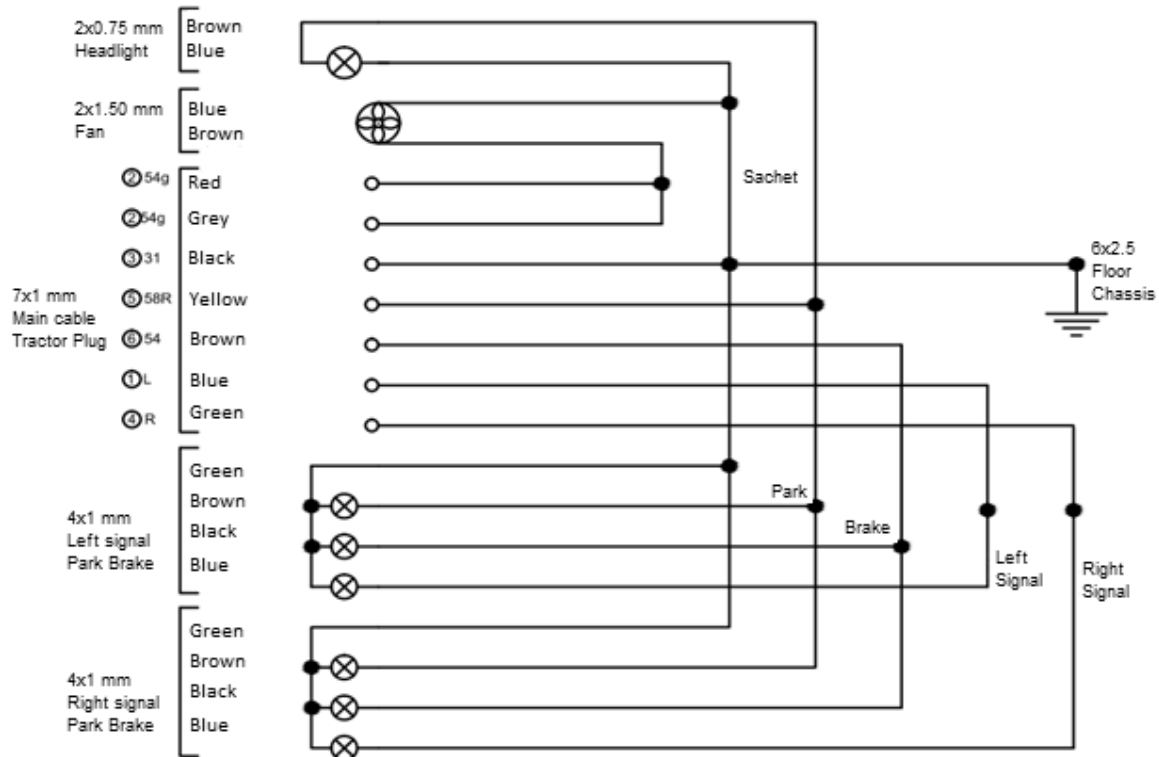

6.1. Hydraulic Circuit Diagram

Hydraulic diagram is shown at Table 6.5.1.

Table 6.5.1. Hydraulic Diagram

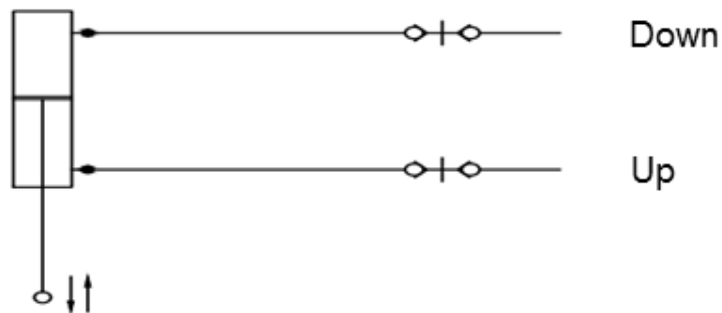

7. WIRE MACHINE SETTING GUIDE

7.1. Iron Wire Connection

Please always keep the wire in oil if you desire to get high-quality press. The pulleys are to be in diameter not more than 320 mm and in length not more than 160 mm. Always control the bobbins are wrapped outstandingly, so you prevent occurring of harmful knots hindering the runnings of connections well.

Place wire bobbins into the box properly as shown in Picture 65 A, before making one or two connections split, pull the points of contact while placing the bobbins into boxes. For this, reeve the wire as shown in below diagram;

1. Take the wire tip of wire bobbin (shown with C), reeve through pin (shown with M), wrap around the pulley (shown with D), pass through pulley (shown with F) and axis (shown with R), link the tip of wire to lama (shown with L).
2. Take the tip of wire from bobbin (shown with O), pass through pin (shown with N), wrap around the pulley (shown with E), pass through pulley (shown with G) and axis (shown with R), link the tip of wire to lama (shown with L).
3. Set in motion connection leverage (shown with F), round the wheel by hand in order to provide needles keeping wires in link to circuit a entire round.
4. Please do not forget to clean lama steel (shown with L) after breaking wires.
5. Machine is now ready to run.

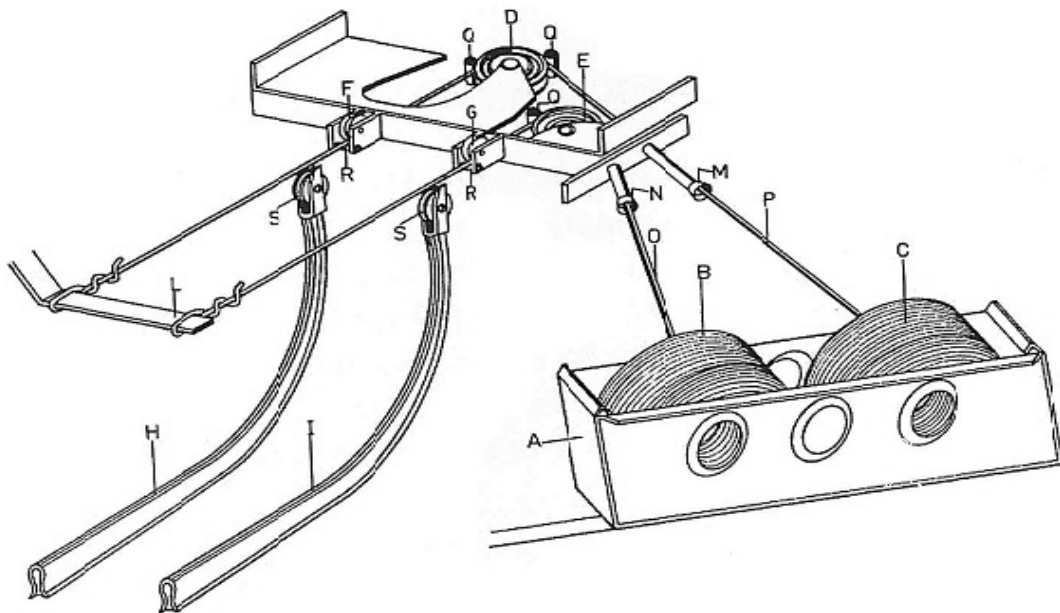
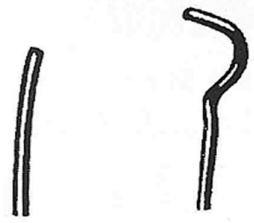
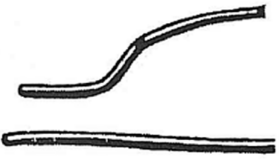
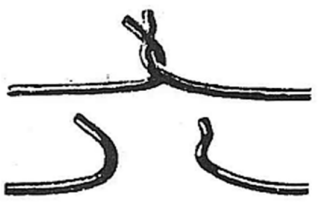

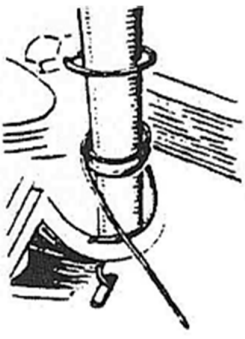
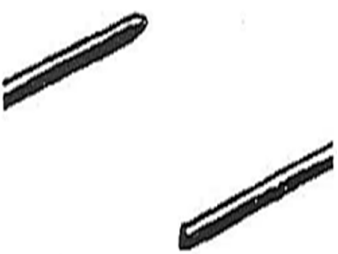

Diagram: Wire Group of Wired Machine

Troubleshooting table of wired knotting group is shown below Table 7.1.1.

Table 7.1.1 Troubleshooting Table of Wired Knotting Group

 <p>Wires are not curved, one tip is cut slippery, the other one is bent and cut.</p>	<p>Wire reeved through needle seises at contortion while passing through press tunnel by material.</p> <p>Feeding is very important at every motion because feeding has been insufficient.</p> <p>Wire is not slippery.</p>	<p>Increase piston displacement as machine type at page 2</p> <p>Clean all around of wire and grease.</p>
 <p>Wires are not convoluted, one tip is cut slippery, the other one is bent and cut; but here are brighter scratches as far as pliers at the end of wire</p>	<p>Wire is not tightened enough with pliers.</p>	<p>Fix pliers stopping wire by turning up pressure</p>
 <p>Not convoluted enough, because too short.</p>	<p>Wire is rusted or lack of grease.</p> <p>Curling is delayed.</p>	<p>Sop wire bobbin into grease. Purify curling section from the probable residues.</p> <p>Pe prepared in advance for one tooth of curling section.</p>
	<p>Wire is not slippery.</p> <p>Curling has been early.</p>	<p>Fix the path that wire passes and grease.</p> <p>Act for one tooth of curling section late.</p>

 <p>If bale is produced without wire from one or two edges</p>	<p>Needle does not reeve wire through pliers.</p> <p>Needle is located wrong from the sideways.</p>	<p>Please follow the instructions for the spacing of wood bender.</p>
 <p>If wire is wrapped around of wood bender, bale is produced without wire</p>	<p>Pliers is not mounted properly that will stop wire and consequently not cut</p> <p>Needle head is too loose Needle is located wrong from the sideways.</p> <p>Not at the phase of curling or early or late yet</p>	<p>Please follow the instructions.</p> <p>Also follow the instructions for the interval of wood bender.</p> <p>Correct the position of needle before starting curling process.</p>
 <p>If not curved, If one tip is broken or slipped, the other tip is broken and disconnected</p>	<p>Wire had been cut before curling and a small piece of wire remained within the pliers.</p> <p>The packet of wire had been wrapped and be blocked in the box.</p> <p>Wire is rusted or remained without grease.</p> <p>Wire is not slippery.</p> <p>High-rate moisture for pressing the material.</p> <p>Wire is sauted outwards.</p>	<p>Open the package and reeve the wire through binder.</p> <p>Sop the wire packages into the grease and keep them always greased.</p> <p>Clean the all around of wire and grease, renew if necessary.</p> <p>Lower the level of press in the tunnel and produce shorter bales.</p> <p>Reeve the wire through pulley and binder.</p> <p>Strengthen the axis of Guidage and renew the used parts.</p>

7.2. Wire Knotter Group Setting

Adjustment of needle is shown at below Figure 68. Please be sure that the machine is not running while making the adjustments

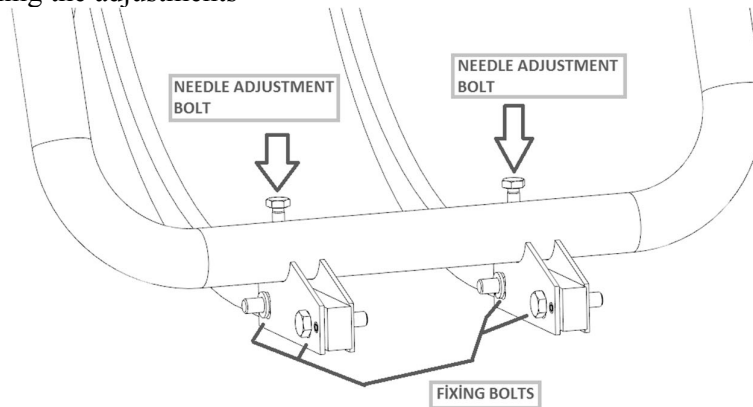

Figure 68: Needle Adjustment Bolts of Wired Machine

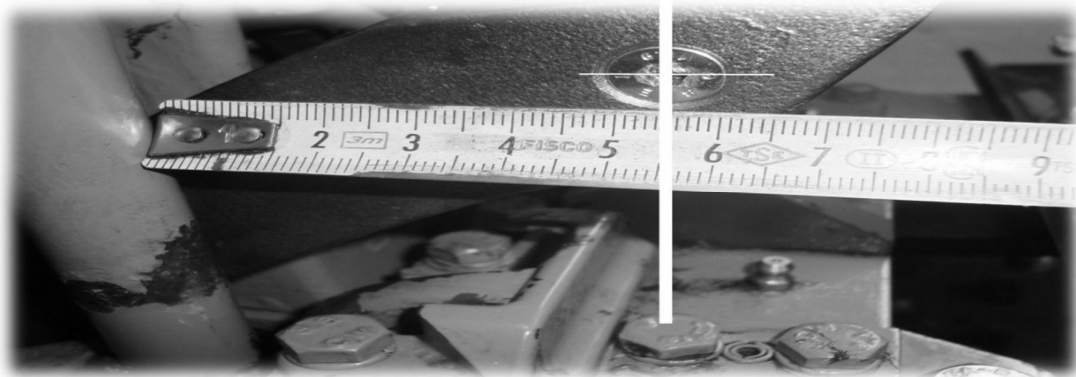

Figure 69 Adjustment Bolts

Needles are set to upper position and calibrated in adjustment bolts as 55mm by unscrewing fixing bolts as seen in Figure 69. Making adjustment must be checked absolutely after the end of this process.

Regular adjustments should be made for settings of centre and timing.

7.3. Wire Knotter Needle Saddle Setting

First loosen the Locking bolt. Set the distance shown on the Photo to 520mm by removing the pins connected to Saddle.

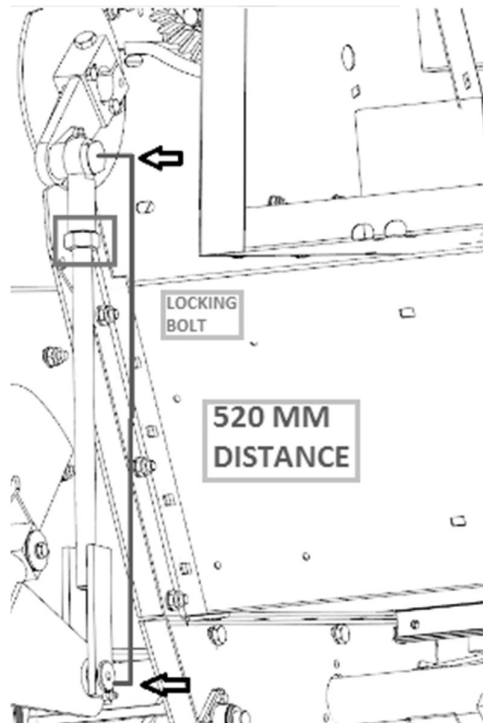

NOTE: TEST THE SADDLE MOWING BEFORE STARTING THE MACHINE

8. CASES NOT COVERED BY THE GUARANTEE AND SECTIONS

Using your machine over the products that unsuited with intended use (like corn, peanut, chaff bale with soil etc.) and in case of malfunctions deriving from damages due to usage such products are out of warranty cover.

The malfunctions and damages that might arise from required adjustment, correction and maintenances by customer are out of warranty.





The malfunction and damages that come out from reparations and maintenances out of authorised service with unoriginal spare parts.



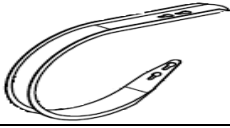

- 1- **TYRE:** The damages and malfunctions that arising from lacking or excessive tyre air pressure than suggested one and form of land (such as rough, rocky, swamp, etc.) are out of warranty cover.
- 2- **SHAFT:** The damages and malfunctions that arising from breaking of shaft as a result of running of the machine out of suggested cycle, bending of shaft resulting from running of hydraulic layout in direction of up or down apart from a particular parallelism during working of tail axle while the machine is connected to tractor.
- 3- **BLADE:** The damages and malfunctions that might arise from the form of land (such as rough, rocky, swamp, etc.) which machine is running on and the defects that might be occurred of melding foreign substance into the machine are out of warranty cover.
- 4- **MALFUNCTION OF ELECTRICITY OR ENGINE:** The malfunctions originating from high or low voltage of tractor electricity or incorrect connections done by unlicensed people are out of warranty cover.
- 5- **BEARING, GEAR, CHAIN and PICKER GROUP:** The damages and malfunctions that might arise from not doing daily, seasonal grease and grease maintenance or running of the machine on lower or higher cycles than remarked status in the user guide of the machine are out of warranty cover.

9. LIST OF SPARE PARTS

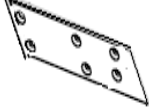
The list of common spare parts of machines with twine and wire is shown below Table 9.1.

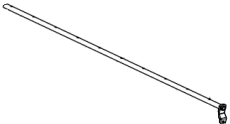

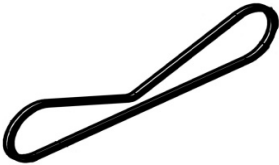
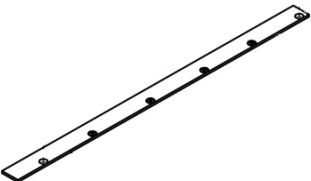

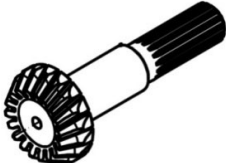
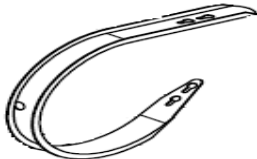



Table 9.1: Common spare parts of machines with twine and wire









No:	Picture of Spare Part	Number of Spare Part	Description	Average Annual Pcs Sent
1		710102140014	Picking Spring	5
2		710102150003	Picking Plate Slim	5
3		710102050009	Lining Ø152xØ102x4	1
4		710102100007	Bearing 62304 2RS 2	2
5		710102100001	Piston Blade 1	1
6		710102140020	Bearing - 62201 2RS 2	2
7		710102080017	Fixed Blade 1	1
8		710102140021	Roller Bearing - SBPFL 205	-





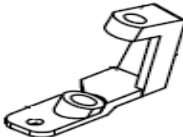

9		710102140009	Picker Spring Tube	-
10		710102110012	Steel Coated Bush 1	1
11		710102140022	Picker rail housing	-
12		710102340024	Rear hayfork transmission chain 3/4" ASA 60	-
13		710102080001	Base right skid sheet iron 1	1
14		710102220003	Small bevel drive gear (Z:35 panel)	-
15		710102220004	Small bevel drive axle (Conical)	--
16		710102150002	Picker plate thick	-

The list of spare parts of machine with twine is shown below Table 9.2.

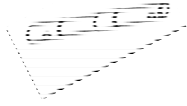
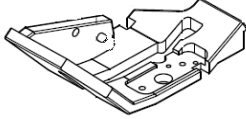
Table 9.2: The list of spare parts of machine with twine





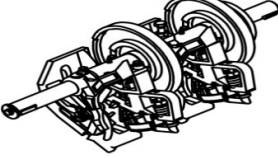

No:	Picture of Spare Part	Number of Spare Part	Description	Average Annual Pcs Sent
1		710102240003	Twine-cutter Knife	1
2		710102230032	Needle	2
3		710102250012	Shuttle Spring	2
4		710102240022	Wrapped Pin	1
5		710102250011	Wrapped Pin	1
6		710102240020	Hook point	1
7		710102250007	Fork	1
8		710102120015	Twine collimator	1

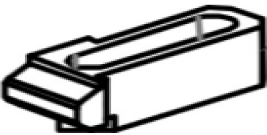
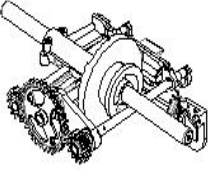

9		710102240004	Star-type press	1
10		710102240006	Star	1
11		710102240017	Knotting Group Cocking Spring 3.5 mm	-
12		710102240012	Knotting press spring	-
13		710102240023	Pinion	-
14		710102240010	Grand gear	-
15		710102250017	Twine stripper body montaged	-
16		710102250006	Twine stripper	1
17		710102410041	Twine feeder compression spring 2 mm	-
18		710102250003	Twine stripper body	1

19		710102250002	Twine stripper axle	1
20		710102250001	Twine knotter lower table	-
21		710102250008	Twine stripper star	-
22		710102240019	Hook	-
23		710102240002	Spring support	-
24		710102210016	Capsule gear	-
25		710102210011	Hammer Capsule gear	-
26		710102210021	Knotting Layout	-

The list of spare parts of machine with wire is shown below Table 9.3.

Table 9.3: The list of spare parts of machine with wire

No:	Picture of Spare Part	Number of Spare Part	Description	Average Annual Pcs Sent
1		710102230042	Needle	1
2		710102520033	Wire cutter knife	1
3		710102520031	Wire clipper stand	1
4		710102520056	Wired Knotting Layout	-
5		710102520024	Catch Hook	1
6		710102520037	Ø6X30 Wrapped Pin	2
7		710102310007	Ø6X35 Wrapped Pin	2
8		710102520040	6201 2 RS Bearing	1

9		710102230045	Needle pulley	2
10		710102520011	Plastic Stopper 21,5X25X20	2

NOTES

NOTES

10. STARTUP SAFETY PRE-INFORMATION FORM

SAFETY

Most of the agricultural layout accidents can be prevented by taking care some simple safety precautions.

- Please do not any cleaning, greasing or any other adjustment on baler machine while it is on running mode or engine of tractor is running. Please find out whether there are rolling parts by listening and looking.
- Please do not activate clutch unless you ensure that everybody is away from the machine and no maintenance kit on the machine.
- Do not work near the baler machine with loose-fitting dress that might squash to moving parts.
- Do not endeavor to hold straw by pulling from any section of the baler machine running on.
- Do not fuel reservoir up while the engine of tractor is running pulling the baler machine.
- Please do not use the baler machine unless all the safeguards are settled.
- Please do not allow anybody to stand on the baler machine.
- Please do not remove the connection of the baler machine while running.
- Do not come near the machine after stopping it for at least two minutes.

Qualification and Training of the Staff

The staff using, maintaining and repairing the baler machine should be warned against to hazards that they might come across during the operation of machine and trained before those. The operator must take the responsibility and watch over the staff. If the personnel are lacking of required knowledge, they should get the necessary training and briefing at once. The operator is obliged to make sure the contents of this guide are understood by the personnel. **The unspecified reparations in this guide should be made by only the authorised services.**

Failure on Implementation of Safety Precautions

In case of not taking safety precautions into consideration, personal injuries and environmental hazards might be occur as well as damage of machine. No implementation of safety precautions can be concluded with ignoring all the allegations of getting damage.

Those dangers may be posed in case of not following safety precautions:

- Posing risks to people at preserving working area by mistake
- Missing of significant specifications of the machine
- Failure on implementation of suggested methods for repair and maintenance
- The hazards that might occur due to mechanical and chemical effects
- Environmental damage that might originate from hydraulic grease leakage

Secure and conscient working

- Please follow the safety precautions in this guide, existing accident preventer regulations as well as any internal works and the operation and safety rules determined by the operator.
- Safety and the accident preventer regulations of liable professional connections match together.
- Safety precautions provided by producer of the vehicle should be watched over as well.
- Applicable traffic rules on the roads that open to the general public should be followed.

11. THE OPERATION SUITABLE FOR INTENDED USAGE

Baler Machines are designed only for standard agricultural usage. Any other different usage is not comply with intended usage. The producer must not be regarded responsible of a damage originating from an unproper usage basing operator's own risk.

Usable bale substances: Grass-derived substances such as grass and straw using for animal production. The warranty conditions are not valid in case of using excluding those purposes and on unsuitable products (such as corn, peanut, cane and bale of chaff, etc).

11.1. Terms of Guarantee

Reference is made to the general guarantee conditions found enclosed with the purchase contract signed by you.

11.2. General Technical Information

- Vehicle driving is allowed only if bale chamber is empty.
- The maximum speed allowed: 20 km/h
- For the machines missing brake, the weight of tractor's tare should sort together with allowed terms of references or at least with the weight of tare of baler.

Minimum Power Requirement :45 HP
Tail Axle Cycle : 540 c/m max.

INFORMATION OF THE MACHINE			
Name of Machine :			
Date of Production :			
Sachet ID No:			
INFORMATION OF AUTHORIZED SERVICE		INFORMATION OF CUSTOMER	
Service's Name:		Identity Number:	
		Name and Surname:	
Contact Phone Number:		Contact Phone Number:	
Address:		Address:	
Explanation:		Explanation:	
Seal and Signature:		Signature:	

**USATE SEMPRE RICAMBI ORIGINALI
ALWAYS USE ORIGINAL SPARE PARTS
IMMER DIE ORIGINAL-ERSATZTEILE VERWENDEN
EMPLOYEZ TOUJOURS LES PIECES DE RECHANGE ORIGINALES
UTILIZAR SIEMPRE REPUESTOS ORIGINALES**



**Servizio Assistenza Tecnica - After Sales Service
Servizio Ricambi - Spare Parts Service**



maschio.com

DEALER:



MASCHIO Fienagione S.p.A.
Sede legale Cremona
Via Bredina, 6 - 26100 Cremona (Italy)
Tel. +39 0372 564610
Fax +39 0372 564625
info@maschio.com

ООО МАСКИО-ГАСПАРДО РУССИЯ
404130, ВОЛЖСКИЙ,
ВОЛГОГРАДСКАЯ обл.,
УЛ. ПУШКИНА, 117 Б., РОССИЯ
TEL. +7 8443 203100
FAX +7 8443 203101
info@maschio.ru

**MASCHIO-GASPARDO
ROMANIA S.R.L**
Strada Înfrățirii, F.N.
315100 Chisineu-Cris (Arad) - România
Tel. +40 257 307030
Fax +40 257 307040
info@maschio.ro

**MASCHIO GASPARDO
Poland sp z.o.o.**
Ul. Wapienna 6/8 - 87 - 100 Torun
Poland
Tel. +48 56 6506051
Fax +48 56 6506053
www.gaspardo.pl

**MASCHIO GASPARDO
NORTH AMERICA, Inc.**
112 3rd Avenue East
Dewitt IA 52742 - USA
Tel. +1 563 6596400
Fax +1 563 6596405
info@maschio.us

MASCHIO FRANCE Sarl
1, Rue de Mérignan ZA
F - 45240 La Ferte St. Aubin
France
Tel. +33 (0) 2.38.64.12.12
Fax +33 (0) 2.38.64.66.79
info@maschio.fr

MASCHIO IBERICA S.L.
**MASCHIO DEUTSCHLAND GMBH MASCHIO-
GASPARDO UCRAINA**
GASPARDO-MASCHIO TURCHIA
MASCHIO-GASPARDO CINA
MASCHIO-GASPARDO INDIA